

# 16

## Modulation and Demodulation

- 16.1 Radio Broadcasting, Transmission and Reception
- 16.2 Modulation
- 16.3 Types of Modulation
- 16.4 Amplitude Modulation
- 16.5 Modulation Factor
- 16.6 Analysis of Amplitude Modulated Wave
- 16.7 Sideband Frequencies in AM Wave
- 16.8 Transistor AM Modulator
- 16.9 Power in AM Wave
- 16.10 Limitations of Amplitude Modulation
- 16.11 Frequency Modulation
- 16.12 Theory of Frequency Modulation
- 16.13 Comparison of FM and AM
- 16.14 Demodulation
- 16.15 Essentials in Demodulation
- 16.16 A.M. Diode Detector
- 16.17 A.M. Radio Receivers
- 16.18 Types of A. M. Radio Receivers
- 16.19 Stages of Superhetrodyne Radio Receiver
- 16.20 Advantages of Superhetrodyne Circuit
- 16.21 FM Receiver
- 16.22 Difference Between FM And AM Receivers



### INTRODUCTION

In radio transmission, it is necessary to send audio signal (*e.g.* music, speech etc.) from a broadcasting station over great distances to a receiver. This communication of audio signal does not employ any wire and is sometimes called *wireless*. The audio signal cannot be sent directly over the air for appreciable distance. Even if the audio signal is converted into electrical signal, the latter cannot be sent very far without employing large amount of power. The energy of a wave is directly proportional to its frequency. At audio frequencies (20 Hz to 20 kHz), the signal power is quite small and radiation is not practicable.

The radiation of electrical energy is practicable only at high frequencies *e.g.* above 20 kHz. The high frequency signals can be sent thousands of miles even with comparatively small power. Therefore, if audio signal is to be

## 412 ■ Principles of Electronics

transmitted properly, some means must be devised which will permit transmission to occur at high frequencies while it simultaneously allows the carrying of audio signal. This is achieved by superimposing electrical audio signal on high frequency carrier. The resultant waves are known as *modulated waves* or *radio waves* and the process is called *modulation*. At the radio receiver, the audio signal is extracted from the modulated wave by the process called *demodulation*. The signal is then amplified and reproduced into sound by the loudspeaker. In this chapter, we shall focus our attention on the various aspects of modulation and demodulation.

### 16.1 Radio Broadcasting, Transmission and Reception

Radio communication means the radiation of radio waves by the transmitting station, the propagation of these waves through space and their reception by the radio receiver. Fig. 16.1 shows the general principles of radio broadcasting, transmission and reception. As a matter of convenience, the entire arrangement can be divided into three parts viz. *transmitter*, *transmission of radio waves* and *radio receiver*.

**1. Transmitter.** Transmitter is an extremely important equipment and is housed in the broadcasting station. Its purpose is to produce radio waves for transmission into space. The important components of a transmitter are microphone, audio amplifiers, oscillator and modulator (See Fig. 16.1).

(i) **Microphone.** A microphone is a device which converts sound waves into electrical waves. When the speaker speaks or a musical instrument is played, the varying air pressure on the microphone generates an audio electrical signal which corresponds in frequency to the original signal. The output of microphone is fed to a multistage audio amplifier for raising the strength of weak signal.

(ii) **Audio amplifier.** The audio signal from the microphone is quite weak and requires amplification. This job is accomplished by cascaded audio amplifiers. The amplified output from the last audio amplifier is fed to the modulator for rendering the process of modulation.

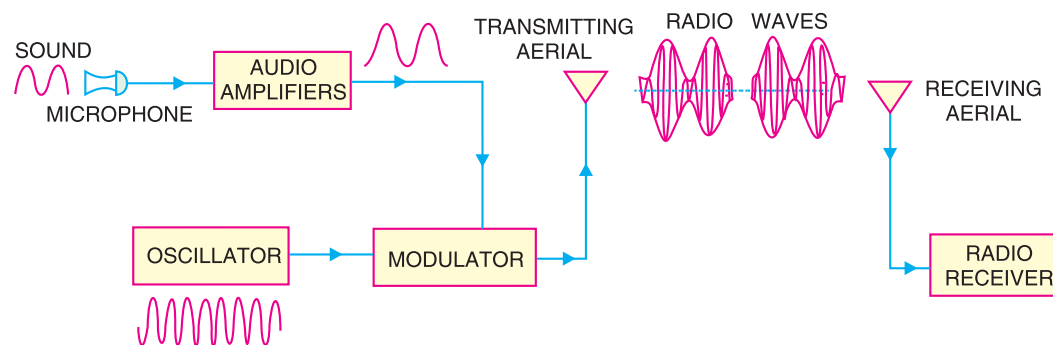

Fig. 16.1

(iii) **Oscillator.** The function of oscillator is to produce a high frequency signal, called a *carrier wave*. Usually, a crystal oscillator is used for the purpose. The power level of the carrier wave is raised to a sufficient level by radio frequency amplifier stages (not shown in Fig. 16.1). Most of the broadcasting stations have carrier wave power of several kilowatts. Such high power is necessary for transmitting the signal to the required distances.

(iv) **Modulator.** The amplified audio signal and carrier wave are fed to the modulator. Here, the audio signal is superimposed on the carrier wave in a suitable manner. The resultant waves are called *modulated waves* or *radio waves* and the process is called *modulation*. The process of modulation permits the transmission of audio signal at the carrier frequency. As the carrier frequency is very high, therefore, the audio signal can be transmitted to large distances. The radio waves from the transmitter are fed to the transmitting antenna or aerial from where these are radiated into space.

**2. Transmission of radio waves.** The transmitting antenna radiates the radio waves in space in all directions. These radio waves travel with the velocity of light *i.e.*  $3 \times 10^8$  m/sec. The radio waves are electromagnetic waves and possess the same general properties. These are similar to light and heat waves except that they have longer wavelengths. It may be emphasised here that radio waves are sent without employing any wire. It can be easily shown that at high frequency, electrical energy can be radiated into space.

**3. Radio receiver.** On reaching the receiving antenna, the radio waves induce tiny e.m.f. in it. This small voltage is fed to the radio receiver. Here, the radio waves are first amplified and then signal is extracted from them by the process of *demodulation*. The signal is amplified by audio amplifiers and then fed to the speaker for reproduction into sound waves.

## 16.2 Modulation

As discussed earlier, a high frequency carrier wave is used to carry the audio signal. The question arises how the audio signal should be “added” to the carrier wave. The solution lies in changing some characteristic of carrier wave in accordance with the signal. Under such conditions, the audio signal will be contained in the resultant wave. This process is called modulation and may be defined as under :

*The process of changing some characteristic (e.g. amplitude, frequency or phase) of a carrier wave in accordance with the intensity of the signal is known as **modulation**.*

Modulation means to “change”. In modulation, some characteristic of carrier wave is changed in accordance with the intensity (*i.e.* amplitude) of the signal. The resultant wave is called modulated wave or radio wave and contains the audio signal. Therefore, modulation permits the transmission to occur at high frequency while it simultaneously allows the carrying of the audio signal.

**Need for modulation.** Modulation is extremely necessary in communication system due to the following reasons :

(i) **Practical antenna length.** Theory shows that in order to transmit a wave effectively, the length of the transmitting antenna should be approximately equal to the wavelength of the wave.

$$\text{Now, wavelength} = \frac{\text{velocity}}{\text{frequency}} = \frac{3 \times 10^8}{\text{frequency (Hz)}} \text{ metres}$$

As the audio frequencies range from 20 Hz to 20 kHz, therefore, if they are transmitted directly into space, the length of the transmitting antenna required would be extremely large. For instance, to radiate a frequency of 20 kHz directly into space, we would need an antenna length of  $3 \times 10^8 / 20 \times 10^3 = 15,000$  metres. This is too long antenna to be constructed practically. For this reason, it is impracticable to radiate audio signal directly into space. On the other hand, if a carrier wave say of 1000 kHz is used to carry the signal, we need an antenna length of 300 metres only and this size can be easily constructed.

(ii) **Operating range.** The energy of a wave depends upon its frequency. The greater the frequency of the wave, the greater the energy possessed by it. As the audio signal frequencies are small, therefore, these cannot be transmitted over large distances if radiated directly into space. The only practical solution is to modulate a high frequency carrier wave with audio signal and permit the transmission to occur at this high frequency (*i.e.* carrier frequency).

(iii) **Wireless communication.** One desirable feature of radio transmission is that it should be carried without wires *i.e.* radiated into space. At audio frequencies, radiation is not practicable because the efficiency of radiation is poor. However, efficient radiation of electrical energy is possible at high frequencies ( $> 20$  kHz). For this reason, modulation is always done in communication systems.

### 16.3 Types of Modulation

As you will recall, modulation is the process of changing amplitude or frequency or phase of a carrier wave in accordance with the intensity of the signal. Accordingly, there are three basic types of modulation, namely ;

- (i) amplitude modulation      (ii) frequency modulation      (iii) phase modulation

In India, amplitude modulation is used in radio broadcasting. However, in television transmission, frequency modulation is used for sound signal and amplitude modulation for picture signal. Therefore, our attention in this chapter shall be confined to the first two most important types of modulation.

### 16.4 Amplitude Modulation

When the amplitude of high frequency carrier wave is changed in accordance with the intensity of the signal, it is called **amplitude modulation**.

In amplitude modulation, only the amplitude of the carrier wave is changed in accordance with the intensity of the signal. However, the frequency of the modulated wave remains the same *i.e.* carrier frequency. Fig. 16.2 shows the principle of amplitude modulation. Fig. 16.2 (i) shows the audio electrical signal whereas Fig. 16.2 (ii) shows a carrier wave of constant amplitude. Fig. 16.2 (iii) shows the amplitude modulated (AM) wave. Note that the amplitudes of both positive and negative half-cycles of carrier wave are changed in accordance with the signal. For instance, when the signal is increasing in the positive sense, the amplitude of carrier wave also increases. On the other hand, during negative half-cycle of the signal, the amplitude of carrier wave decreases. Amplitude modulation is done by an electronic circuit called *modulator*.

The following points are worth noting in amplitude modulation :

- (i) The amplitude of the carrier wave changes according to the intensity of the signal.
- (ii) The amplitude variations of the carrier wave is at the signal frequency  $f_s$ .
- (iii) The frequency of the amplitude modulated wave remains the same *i.e.* carrier frequency  $f_c$ .

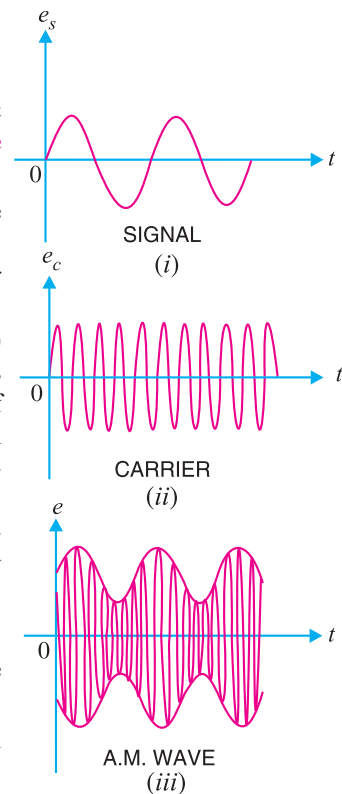

Fig. 16.2

### 16.5 Modulation Factor

An important consideration in amplitude modulation is to describe the depth of modulation *i.e.* the extent to which the amplitude of carrier wave is changed by the signal. This is described by a factor called modulation factor which may be defined as under :

The ratio of change of amplitude of carrier wave to the amplitude of normal carrier wave is called the **modulation factor**  $m$  *i.e.*

$$\text{Modulation factor, } m = \frac{\text{Amplitude change of carrier wave}}{\text{Normal carrier amplitude (unmodulated)}}$$

The value of modulation factor depends upon the amplitudes of carrier and signal. Fig. 16.3 shows amplitude modulation for different values of modulation factor  $m$ .

- (i) When signal amplitude is zero, the carrier wave is not modulated as shown in Fig. 16.3 (i). The amplitude of carrier wave remains unchanged.

Amplitude change of carrier = 0

Amplitude of normal carrier = A

∴ Modulation factor,  $m = 0/A = 0$  or 0%

(ii) When signal amplitude is equal to the carrier amplitude as shown in Fig. 16.3 (ii), the amplitude of carrier varies between 2A and zero.

Amplitude change of carrier =  $2A - A = A$

∴ Modulation factor,  $m = \frac{\text{Amplitude change of carrier}}{\text{Amplitude of normal carrier}} = A/A = 1$  or 100%

In this case, the carrier is said to be 100% modulated.

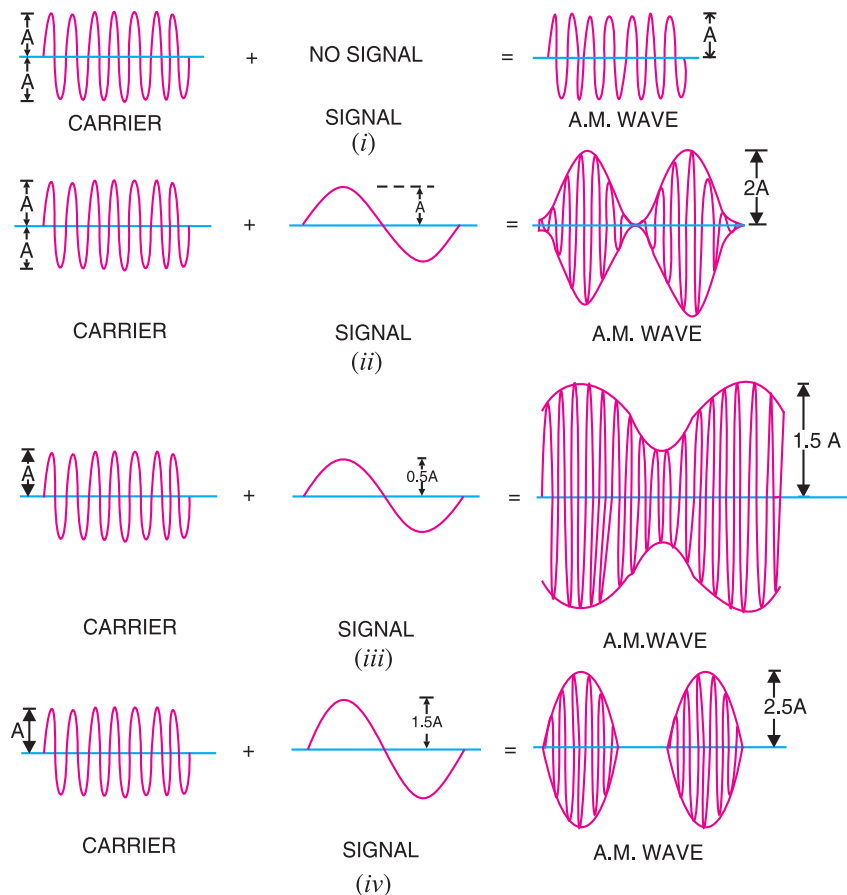

Fig. 16.3

(iii) When the signal amplitude is one-half the carrier amplitude as shown in Fig. 16.3 (iii), the amplitude of carrier wave varies between 1.5 A and 0.5 A.

Amplitude change of carrier =  $1.5A - A = 0.5A$

∴ Modulation factor,  $m = 0.5A/A = 0.5$  or 50%

In this case, the carrier is said to be 50% modulated.

(iv) When the signal amplitude is 1.5 times the carrier amplitude as shown in Fig. 16.3 (iv), the maximum value of carrier wave becomes 2.5 A.

Amplitude change of carrier wave =  $2.5A - A = 1.5A$

## 416 ■ Principles of Electronics

$$\therefore \text{Modulation factor, } m = \frac{1.5 A}{A} = 1.5 \text{ or } 150 \%$$

In this case, the carrier is said to be 150% modulated *i.e.* over-modulated.

**Importance of modulation factor.** Modulation factor is very important since it determines the strength and quality of the transmitted signal. In an AM wave, the signal is contained in the variations of the carrier amplitude. When the carrier is modulated to a small degree (*i.e.* small  $m$ ), the amount of carrier amplitude variation is small. Consequently, the audio signal being transmitted will not be very strong. The greater the degree of modulation (*i.e.*  $m$ ), the stronger and clearer will be the audio signal. It may be emphasised here that if the carrier is overmodulated (*i.e.*  $m > 1$ ), distortion will occur during reception. This condition is shown in Fig. 16.3 (*iv*). The AM waveform is clipped and the envelope is discontinuous. Therefore, degree of modulation should never exceed 100%.

**Example 16.1.** If the maximum and minimum voltage of an AM wave are  $V_{max}$  and  $V_{min}$  respectively, then show that modulation factor  $m$  is given by :

$$m = \frac{V_{max} - V_{min}}{V_{max} + V_{min}}$$

**Solution.** Fig. 16.4 shows the waveform of amplitude modulated wave. Let the amplitude of the normal carrier wave be  $E_C$ . Then, it is clear from Fig. 16.4 that :

$$E_C = \frac{V_{max} + V_{min}}{2}$$

If  $E_S$  is the signal amplitude, then it is clear from Fig. 16.4 that :

$$E_S = \frac{V_{max} - V_{min}}{2}$$

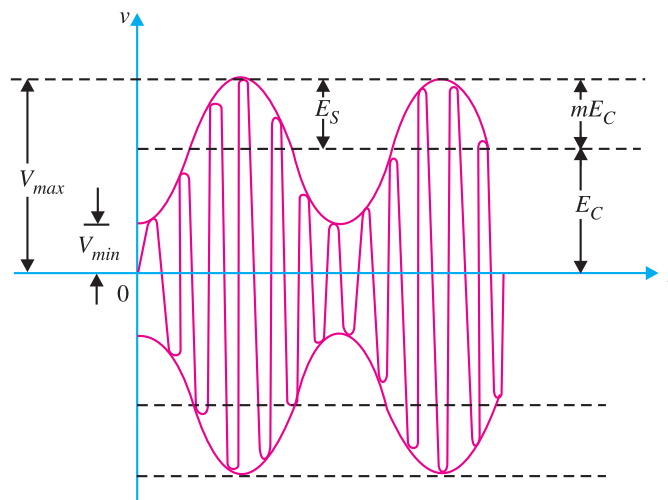

**Fig. 16.4**

But

$$E_S = m E_C$$

or

$$\frac{V_{max} - V_{min}}{2} = m \frac{V_{max} + V_{min}}{2} \quad \text{or} \quad m = \frac{V_{max} - V_{min}}{V_{max} + V_{min}}$$

**Example 16.2.** The maximum peak-to-peak voltage of an AM wave is 16 mV and the minimum peak-to-peak voltage is 4 mV. Calculate the modulation factor.

**Solution.** Fig. 16.5 shows the conditions of the problem.

Maximum voltage of AM wave is

$$V_{max} = \frac{16}{2} = 8 \text{ mV}$$

Minimum voltage of AM wave is

$$V_{min} = \frac{4}{2} = 2 \text{ mV}$$

$$\begin{aligned} \therefore \text{Modulation factor, } m &= \frac{V_{max} - V_{min}}{V_{max} + V_{min}} \\ &= \frac{8 - 2}{8 + 2} = \frac{6}{10} = 0.6 \end{aligned}$$

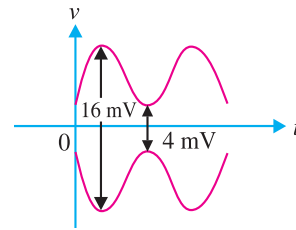

Fig. 16.5

**Example 16.3.** A carrier of 100V and 1200 kHz is modulated by a 50 V, 1000 Hz sine wave signal. Find the modulation factor.

**Solution.**

$$\text{Modulation factor, } m = \frac{E_s}{E_c} = \frac{50 \text{ V}}{100 \text{ V}} = 0.5$$

### 16.6 Analysis of Amplitude Modulated Wave

A carrier wave may be represented by :

$$e_c = E_C \cos \omega_c t$$

where

$e_c$  = instantaneous voltage of carrier

$E_C$  = amplitude of carrier

$$\omega_c = 2 \pi f_c$$

= angular velocity at carrier frequency  $f_c$

In amplitude modulation, the amplitude  $E_C$  of the carrier wave is varied in accordance with the intensity of the signal as shown in Fig. 16.6. Suppose the modulation factor is  $m$ . It means that signal produces a maximum change of  $m E_C$  in the carrier amplitude. Obviously, the amplitude of signal is  $m E_C$ . Therefore, the signal can be represented by :

$$e_s = m E_C \cos \omega_s t$$

where

$e_s$  = instantaneous voltage of signal

$m E_C$  = amplitude of signal

$$\omega_s = 2 \pi f_s = \text{angular velocity at signal frequency } f_s$$

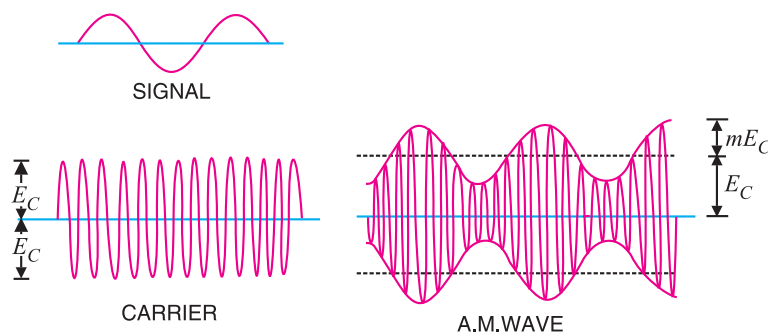

Fig. 16.6



## 418 ■ Principles of Electronics

The amplitude of the carrier wave varies at signal frequency  $f_s$ . Therefore, the amplitude of AM wave is given by :

$$\text{Amplitude of AM wave} = E_C + m E_C \cos \omega_s t = E_C (1 + m \cos \omega_s t)$$

The instantaneous voltage of AM wave is :

$$\begin{aligned} e &= \text{Amplitude} \times \cos \omega_c t \\ &= E_C (1 + m \cos \omega_s t) \cos \omega_c t \\ &= E_C \cos \omega_c t + m E_C \cos \omega_s t \cos \omega_c t \\ &= E_C \cos \omega_c t + \frac{mE_C}{2} (2 \cos \omega_s t \cos \omega_c t) \\ &= E_C \cos \omega_c t + \frac{mE_C}{2} [\cos (\omega_c + \omega_s) t + \cos (\omega_c - \omega_s) t]^* \\ &= E_C \cos \omega_c t + \frac{mE_C}{2} \cos (\omega_c + \omega_s) t + \frac{mE_C}{2} \cos (\omega_c - \omega_s) t \end{aligned}$$

The following points may be noted from the above equation of amplitude modulated wave:

(i) The AM wave is equivalent to the summation of three sinusoidal waves; one having amplitude  $E_C$  and frequency  $f_c$ , the second having amplitude  $mE_C/2$  and frequency  $(f_c + f_s)$  and the third having amplitude  $mE_C/2$  and frequency  $f_c - f_s$ .

(ii) The AM wave contains three frequencies viz.  $f_c, f_c + f_s$  and  $f_c - f_s$ . The first frequency is the carrier frequency. Thus, the process of modulation does not change the original carrier frequency but produces two new frequencies  $(f_c + f_s)$  and  $(f_c - f_s)$  which are called sideband frequencies.

(iii) The sum of carrier frequency and signal frequency i.e.  $(f_c + f_s)$  is called *upper sideband frequency*. The *lower sideband frequency* is  $f_c - f_s$  i.e. the difference between carrier and signal frequencies.

### 16.7 Sideband Frequencies in AM Wave

In an amplitude modulated wave, the sideband frequencies are of our interest. It is because the signal frequency  $f_s$  is contained in the sideband frequencies. Fig. 16.7 shows the frequency spectrum of an amplitude modulated wave. The frequency components in the AM wave are shown by vertical lines. The height of each vertical line is equal to the amplitude of the components present. It may be added here that in practical radio transmission, carrier frequency  $f_c$  is many times greater than signal frequency  $f_s$ . Hence, the sideband frequencies are generally close to the carrier frequency. It may be seen that a carrier modulated by a single frequency is equivalent to three simultaneous signals; the car-

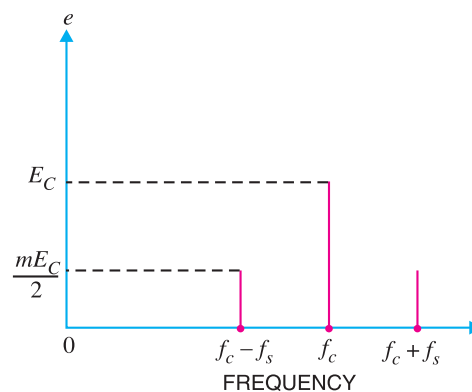

Fig. 16.7

\* From trigonometry, we have the expansion formula :

$$2 \cos A \cos B = \cos (A + B) + \cos (A - B)$$

\*\*  $f_c = \frac{\omega_c}{2\pi}, f_c + f_s = \frac{\omega_c + \omega_s}{2\pi}, f_c - f_s = \frac{\omega_c - \omega_s}{2\pi}$



rier itself and two other steady frequencies *i.e.*  $f_c + f_s$  and  $f_c - f_s$ .

Let us illustrate sideband frequencies with an example. Suppose the carrier frequency is 400 kHz and the signal frequency is 1 kHz. The AM wave will contain three frequencies *viz* 400 kHz, 401 kHz and 399 kHz. It is clear that upper sideband frequency (401 kHz) and lower sideband frequency (399 kHz) are very close to the carrier frequency (400 kHz).

**Bandwidth.** In an AM wave, the bandwidth is from  $(f_c - f_s)$  to  $(f_c + f_s)$  *i.e.*,  $2f_s$ . Thus in the above example, bandwidth is from 399 to 401 kHz or 2 kHz which is twice the signal frequency. Therefore, we arrive at a very important conclusion that *in amplitude modulation, bandwidth is twice the signal frequency*. The tuned amplifier which is called upon to amplify the modulated wave must have the required bandwidth to include the sideband frequencies. If the tuned amplifier has insufficient bandwidth, the upper sideband frequencies may not be reproduced by the radio receiver.

**Example 16.4.** A 2500 kHz carrier is modulated by audio signal with frequency span of 50 – 15000 Hz. What are the frequencies of lower and upper sidebands? What bandwidth of RF amplifier is required to handle the output?

**Solution.** The modulating signal (*e.g.* music) has a range of 0.05 to 15 kHz. The sideband frequencies produced range from  $f_c \pm 0.05$  kHz to  $f_c \pm 15$  kHz. Therefore, upper sideband ranges from 2500.05 to 2515 kHz and lower sideband ranges from 2499.95 to 2485 kHz.

The sideband frequencies produced can be approximately expressed as  $2500 \pm 15$  kHz. Therefore, bandwidth requirement =  $2515 - 2485 = 30$  kHz. Note that bandwidth of RF amplifier required is twice the frequency of highest modulating signal frequency.

### 16.8 Transistor AM \*Modulator

Fig. 16.8 shows the circuit of a simple AM modulator. It is essentially a CE amplifier having a voltage gain of A. The carrier signal is the input to the amplifier. The modulating signal is applied in the emitter resistance circuit.

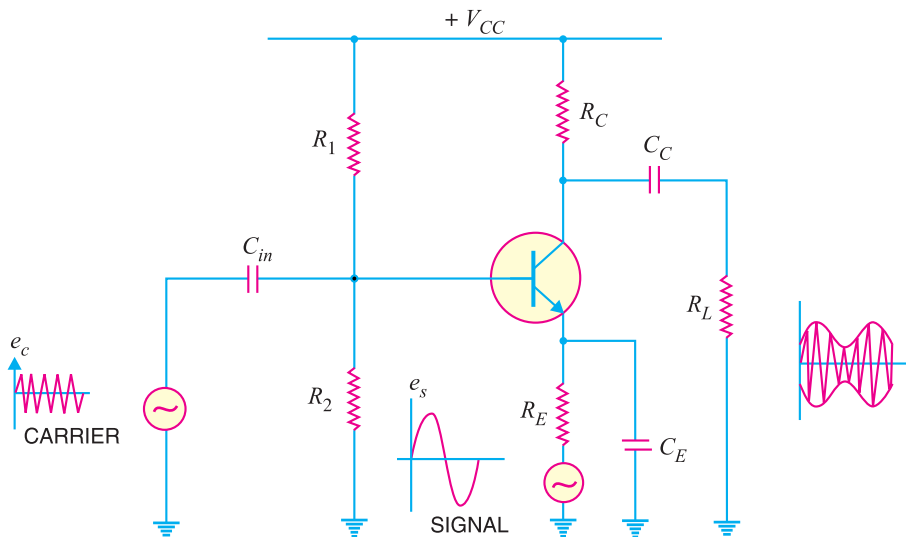

Fig. 16.8

\* A circuit which does amplitude modulation is called AM modulator.

## 420 ■ Principles of Electronics

**Working.** The carrier  $e_c$  is applied at the input of the amplifier and the modulating signal  $e_s$  is applied in the emitter resistance circuit. The amplifier circuit amplifies the carrier by a factor “A” so that the output is  $Ae_c$ . Since the modulating signal is a part of the biasing circuit, it produces low-frequency variations in the emitter circuit. This in turn causes \*variations in “A”. The result is that amplitude of the carrier varies in accordance with the strength of the signal. Consequently, amplitude modulated output is obtained across  $R_L$ . It may be noted that carrier should not influence the voltage gain A; only the modulating signal should do this. To achieve this objective, carrier should have a small magnitude and signal should have a large magnitude.

**Example 16.5.** An AM wave is represented by the expression :

$$v = 5 (1 + 0.6 \cos 6280 t) \sin 211 \times 10^4 t \text{ volts}$$

- (i) What are the minimum and maximum amplitudes of the AM wave ?  
 (ii) What frequency components are contained in the modulated wave and what is the amplitude of each component?

**Solution.**

The AM wave equation is given by :  $v = 5 (1 + 0.6 \cos 6280 t) \sin 211 \times 10^4 t$  volts ... (i)

Compare it with standard AM wave eq.,  $v = E_C (1 + m \cos \omega_s t) \sin \omega_c t$  ... (ii)

From eqs. (i) and (ii) , we get,  $E_C =$  carrier amplitude = 5 V

$m =$  modulation factor = 0.6

$f_s =$  signal frequency =  $\omega_s/2\pi = 6280/2\pi = 1$  kHz

$f_c =$  carrier frequency =  $\omega_c/2\pi = 211 \times 10^4/2\pi = 336$  kHz

(i) Minimum amplitude of AM wave =  $E_C - mE_C = 5 - 0.6 \times 5 = 2$  V

Maximum amplitude of AM wave =  $E_C + mE_C = 5 + 0.6 \times 5 = 8$  V

(ii) The AM wave will contain three frequencies viz.

	$f_c - f_s,$	$f_c,$	$f_c + f_s$
or	336 - 1 ,	336 ,	336 + 1
or	<b>335 kHz,</b>	<b>336 kHz,</b>	<b>337 kHz</b>

The amplitudes of the three components of AM wave are :

	$\frac{mE_C}{2},$	$E_C,$	$\frac{mE_C}{2}$
or	$\frac{0.6 \times 5}{2},$	5,	$\frac{0.6 \times 5}{2}$
or	<b>1.5 V,</b>	<b>5 V,</b>	<b>1.5 V</b>

**Example 16.6.** A sinusoidal carrier voltage of frequency 1 MHz and amplitude 100 volts is amplitude modulated by sinusoidal voltage of frequency 5 kHz producing 50% modulation. Calculate the frequency and amplitude of lower and upper sideband terms.

**Solution.**

Frequency of carrier,  $f_c = 1$  MHz = 1000 kHz

Frequency of signal,  $f_s = 5$  kHz

Modulation factor,  $m = 50\% = 0.5$

\* The principle of this circuit is to change the gain A (and hence the amplitude of carrier) by the modulating signal.

Amplitude of carrier,  $E_C = 100 \text{ V}$

The lower and upper sideband frequencies are :

$$\begin{aligned} & f_c - f_s \text{ and } f_c + f_s \\ \text{or} & (1000 - 5) \text{ kHz and } (1000 + 5) \text{ kHz} \\ \text{or} & \mathbf{995 \text{ kHz}} \text{ and } \mathbf{1005 \text{ kHz}} \end{aligned}$$

$$\text{Amplitude of each sideband term} = \frac{mE_C}{2} = \frac{0.5 \times 100}{2} = \mathbf{25 \text{ V}}$$

**Example 16.7.** A carrier wave of frequency 10 MHz and peak value 10V is amplitude modulated by a 5- kHz sine wave of amplitude 6V. Determine (i) modulation factor (ii) sideband frequencies and (iii) amplitude of sideband components. Draw the frequency spectrum.

**Solution.**

- Carrier amplitude,  $E_C = 10\text{V}$
- Signal amplitude,  $E_S = 6\text{V}$
- Carrier frequency,  $f_c = 10 \text{ MHz}$
- Signal frequency,  $f_s = 5 \text{ kHz} = 0.005 \text{ MHz}$

(i) Modulation factor,  $m = \frac{E_S}{E_C} = \frac{6}{10} = \mathbf{0.6}$

(ii) Sideband frequencies are :

$$\begin{aligned} & f_c - f_s ; f_c + f_s \\ & 10 - 0.005 ; 10 + 0.005 \\ & \mathbf{9.995 \text{ MHz} ; 10.005 \text{ MHz}} \end{aligned}$$

(iii) Amplitude of each sideband =  $\frac{mE_C}{2} = \frac{0.6 \times 10}{2} = \mathbf{3\text{V}}$

Fig. 16.9 shows the frequency spectrum of the A.M. wave.

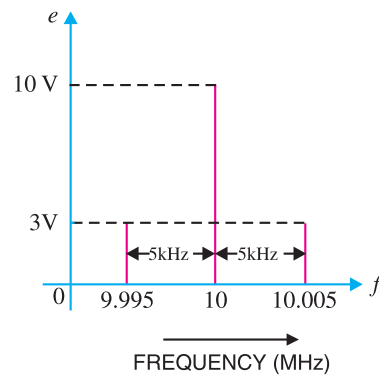

**Fig. 16.9**

### 16.9 Power in AM Wave

The power dissipated in any circuit is a function of the square of voltage across the circuit and the effective resistance of the circuit. Equation of AM wave reveals that it has three components of amplitude  $E_C$ ,  $mE_C/2$  and  $mE_C/2$ . Clearly, power output must be distributed among these components.

$$\text{Carrier power, } P_C = \frac{*(E_C / \sqrt{2})^2}{R} = \frac{E_C^2}{2R} \quad \dots(i)$$

$$\begin{aligned} \text{Total power of sidebands, } P_S &= \frac{(mE_C / 2\sqrt{2})^2}{R} + \frac{(mE_C / 2\sqrt{2})^2}{R} \\ &= \frac{m^2 E_C^2}{8R} + \frac{m^2 E_C^2}{8R} = \frac{m^2 E_C^2}{4R} \quad \dots(ii) \end{aligned}$$

$$\text{Total power of AM wave, } P_T = P_C + P_S$$

\* r.m.s. values are considered.

## 422 ■ Principles of Electronics

$$= \frac{E_C^2}{2R} + \frac{m^2 E_C^2}{4R} = \frac{E_C^2}{2R} \left[ 1 + \frac{m^2}{2} \right]$$

or 
$$P_T = \frac{E_C^2}{2R} \frac{[2 + m^2]}{2} \quad \dots(iii)$$

Fraction of total power carried by sidebands is

$$\frac{P_S}{P_T} = \frac{\text{Exp. (ii)}}{\text{Exp. (iii)}} = \frac{m^2}{2 + m^2} \quad \dots(iv)$$

As the signal is contained in the sideband frequencies, therefore, useful power is in the sidebands. Inspection of exp. (iv) reveals that sideband power depends upon the modulation factor  $m$ . The greater the value of  $m$ , the greater is the useful power carried by the sidebands. This emphasises the importance of modulation factor.

(i) When  $m = 0$ , power carried by sidebands =  $0^2/2 + 0^2 = 0$

(ii) When  $m = 0.5$ , power carried by sidebands

$$= \frac{(0.5)^2}{2 + (0.5)^2} = 11.1 \% \text{ of total power of AM wave}$$

(iii) When  $m = 1$ , power carried by sidebands

$$= \frac{(1)^2}{2 + (1)^2} = 33.3\% \text{ of total power of AM wave}$$

As an example, suppose the total power of an AM wave is 600 watts and modulation is 100%. Then sideband power is  $600/3 = 200$  watts and carrier power will be  $600 - 200 = 400$  watts.

The sideband power represents the signal content and the carrier power is that power which is required as the means of transmission.

**Note.** 
$$P_C = \frac{E_C^2}{2R} \quad \text{and} \quad P_S = \frac{m^2 E_C^2}{4R}$$

$$\therefore \frac{P_S}{P_C} = \frac{1}{2} m^2$$

or 
$$P_S = \frac{1}{2} m^2 P_C \quad \dots(v)$$

Expression (v) gives the relation between total sideband power ( $P_S$ ) and carrier power ( $P_C$ ).

### 16.10 Limitations of Amplitude Modulation

Although theoretically highly effective, amplitude modulation suffers from the following drawbacks:

(i) **Noisy reception.** In an AM wave, the signal is in the amplitude variations of the carrier. Practically all the natural and man made noises consist of electrical amplitude disturbances. As a radio receiver cannot distinguish between amplitude variations that represent noise and those that contain the desired signal, therefore, reception is generally noisy.

(ii) **Low efficiency.** In amplitude modulation, useful power is in the sidebands as they contain the signal. As discussed before, an AM wave has low sideband power. For example, if modulation is 100%, the sideband power is only one-third of the total power of AM wave. Hence the efficiency of this type of modulation is low.

(iii) **Small operating range.** Due to low efficiency of amplitude modulation, transmitters employing this method have a small operating range *i.e.* messages cannot be transmitted over larger distances.

(iv) **Lack of audio quality.** This is a distinct disadvantage of amplitude modulation. In order to attain high-fidelity reception, all audio frequencies up to 15 kHz must be reproduced. This necessitates bandwidth of 30 kHz since both sidebands must be reproduced. But AM broadcasting stations are assigned bandwidth of only 10 kHz to minimise the interference from adjacent broadcasting stations. This means that the highest modulating frequency can be 5 kHz which is hardly sufficient to reproduce the music properly.

**Example 16.8.** A carrier wave of 500 watts is subjected to 100% amplitude modulation. Determine :

- (i) power in sidebands      (ii) power of modulated wave.

**Solution.**

(i) Sideband power,  $P_S = \frac{1}{2} m^2 P_C = \frac{1}{2} \times 500 = 250 \text{ W}$

Thus there are 125 W in upper sideband and 125 W in lower sideband.

(ii) Power of AM wave,  $P_T = P_C + P_S = 500 + 250 = 750 \text{ W}$

**Example 16.9.** A 50 kW carrier is to be modulated to a level of (i) 80% (ii) 10%. What is the total sideband power in each case ?

**Solution. (i)**  $P_S = \frac{1}{2} m^2 P_C = \frac{1}{2} (0.8)^2 \times 50 = 16 \text{ kW}$

(ii)  $P_S = \frac{1}{2} m^2 P_C = \frac{1}{2} (0.1)^2 \times 50 = 0.25 \text{ kW}$

Note the effect of modulation factor on the magnitude of sideband power. In the first case ( $m = 80\%$ ), we generated and transmitted 50 kW carrier in order to send 16 kW of intelligence. In the second case ( $m = 10\%$ ), the same carrier level — 50 kW — is used to send merely 250 W of intelligence. Clearly, the efficiency of operation decreases rapidly as modulation factor decreases. For this reason, in amplitude modulation, the value of  $m$  is kept as close to unity as possible.

**Example 16.10.** A 40kW carrier is to be modulated to a level of 100%.

- (i) What is the carrier power after modulation ?  
 (ii) How much audio power is required if the efficiency of the modulated RF amplifier is 72% ?

**Solution.** Fig. 16.10 shows the block diagram indicating the power relations.

(i) Since the carrier itself is unaffected by the modulating signal, there is no change in the carrier power level.

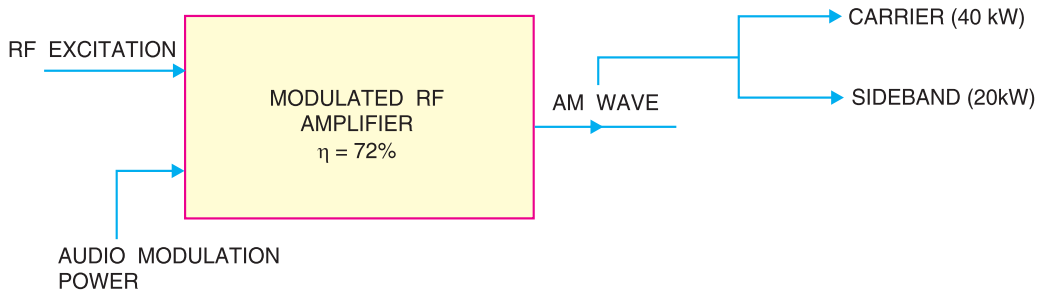

Fig. 16.10

**424 ■ Principles of Electronics**

$$\begin{aligned} \therefore P_C &= \mathbf{40 \text{ kW}} \\ \text{(ii)} \quad P_S &= \frac{1}{2} m^2 P_C = \frac{1}{2} (1)^2 \times 40 = 20 \text{ kW} \\ \therefore P_{\text{audio}} &= \frac{P_S}{0.72} = \frac{20}{0.72} = \mathbf{27.8 \text{ kW}} \end{aligned}$$

**Example 16.11.** An audio signal of 1 kHz is used to modulate a carrier of 500 kHz. Determine (i) sideband frequencies (ii) bandwidth required.

**Solution.** Carrier frequency,  $f_c = 500 \text{ kHz}$

Signal frequency,  $f_s = 1 \text{ kHz}$

(i) As discussed in Art. 16.6, the AM wave has sideband frequencies of  $(f_c + f_s)$  and  $(f_c - f_s)$ .

$$\begin{aligned} \therefore \text{Sideband frequencies} &= (500 + 1) \text{ kHz and } (500 - 1) \text{ kHz} \\ &= \mathbf{501 \text{ kHz and } 499 \text{ kHz}} \end{aligned}$$

(ii) Bandwidth required = 499 kHz to 501 kHz = **2 kHz**

**Example 16.12.** The load current in the transmitting antenna of an unmodulated AM transmitter is 8A. What will be the antenna current when modulation is 40% ?

**Solution.**

$$P_S = \frac{1}{2} m^2 P_C$$

$$P_T = P_C + P_S = P_C \left( 1 + \frac{m^2}{2} \right)$$

$$\therefore \frac{P_T}{P_C} = 1 + \frac{m^2}{2}$$

$$\text{or} \quad \left( \frac{I_T}{I_C} \right)^2 = 1 + \frac{m^2}{2}$$

Given that  $I_C = 8\text{A}$ ;  $m = 0.4$

$$\therefore \left( \frac{I_T}{8} \right)^2 = 1 + \frac{(0.4)^2}{2}$$

$$\text{or} \quad (I_T/8)^2 = 1.08$$

$$\text{or} \quad I_T = 8\sqrt{1.08} = \mathbf{8.31 \text{ A}}$$

**Example 16.13.** The antenna current of an AM transmitter is 8A when only carrier is sent but it increases to 8.93A when the carrier is sinusoidally modulated. Find the % age modulation.

**Solution.** As shown in example 16.12,

$$\left( \frac{I_T}{I_C} \right)^2 = 1 + \frac{m^2}{2}$$

Given that  $I_T = 8.93 \text{ A}$ ;  $I_C = 8 \text{ A}$ ;  $m = ?$

$$\therefore \left( \frac{8.93}{8} \right)^2 = 1 + \frac{m^2}{2}$$

$$\text{or} \quad 1.246 = 1 + m^2/2$$

$$\text{or} \quad m^2/2 = 0.246$$

$$\text{or} \quad m = \sqrt{2 \times 0.246} = 0.701 = \mathbf{70.1\%}$$

**Example 16.14.** The r.m.s. value of carrier voltage is 100 V. After amplitude modulation by a sinusoidal a.f. voltage, the r.m.s. value becomes 110 V. Calculate the modulation index.

**Solution.**

$$\frac{P_T}{P_C} = 1 + \frac{m^2}{2}$$

or

$$\left(\frac{V_T}{V_C}\right)^2 = 1 + \frac{m^2}{2}$$

Given that  $V_T = 110 \text{ V}$ ;  $V_C = 100 \text{ V}$ ;  $m = ?$

$$\therefore \left(\frac{110}{100}\right)^2 = 1 + \frac{m^2}{2}$$

or

$$1.21 = 1 + \frac{m^2}{2}$$

or

$$m^2/2 = 0.21$$

or

$$m = \sqrt{0.21 \times 2} = \mathbf{0.648}$$

**Example 16.15.** An AM wave consists of the following components :

- Carrier component = 5 V peak value
- Lower sideband component = 2.5 V peak value
- Upper sideband component = 2.5 V peak value

If the AM wave drives a 2 kΩ resistor, find the power delivered to the resistor by (i) carrier (ii) lower sideband component and (iii) upper sideband component. What is the total power delivered?

**Solution.** Fig. 16.11 (i) shows the frequency spectrum of AM wave whereas Fig. 16.11 (ii) shows the equivalent circuit.

$$\text{Power} = \frac{(\text{r.m.s. voltage})^2}{R} = \frac{(0.707 \times \text{peak value})^2}{R}$$

(i) Power delivered by the carrier,  $P_C = \frac{(0.707 \times 5)^2}{2000} = \mathbf{6.25 \text{ mW}}$

(ii) Power delivered by lower sideband component is

$$P_{\text{lower}} = \frac{(0.707 \times 2.5)^2}{2000} = \mathbf{1.562 \text{ mW}}$$

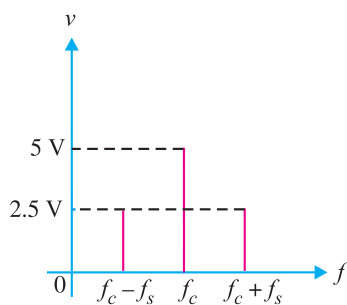

(i)

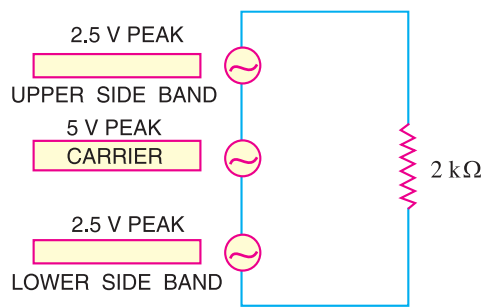

(ii)

**Fig. 16.11**

(iii) Power delivered by upper sideband component is

$$P_{\text{upper}} = \frac{(0.707 \times 2.5)^2}{2000} = \mathbf{1.562 \text{ mW}}$$



Total power delivered by the AM wave =  $6.25 + 1.562 + 1.562 = 9.374 \text{ mW}$

## 16.11 Frequency Modulation (FM)

When the frequency of carrier wave is changed in accordance with the intensity of the signal, it is called **frequency modulation (FM)**.

In frequency modulation, only the frequency of the carrier wave is changed in accordance with the signal. However, the amplitude of the modulated wave remains the same *i.e.* carrier wave amplitude. The frequency variations of carrier wave depend upon the instantaneous amplitude of the signal as shown in Fig. 16.12 (iii). When the signal voltage is zero as at A, C, E and G, the carrier frequency is unchanged. When the signal approaches its positive peaks as at B and F, the carrier frequency is increased to maximum as shown by the closely spaced cycles. However, during the negative peaks of signal as at D, the carrier frequency is reduced to minimum as shown by the widely spaced cycles.

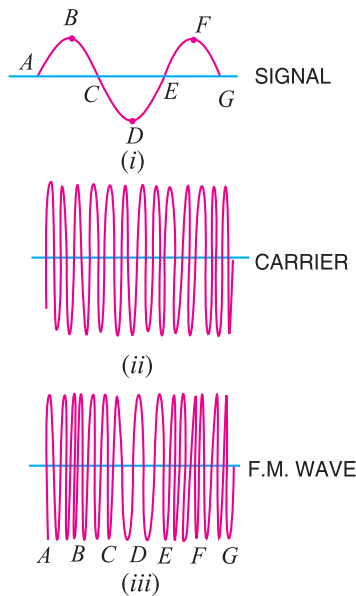

Fig. 16.12

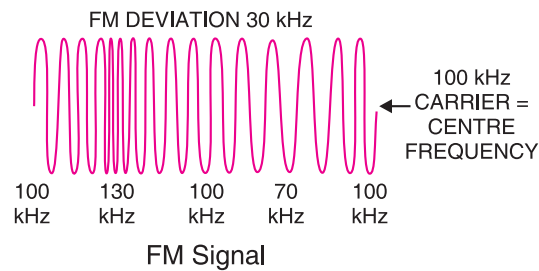

Fig. 16.13

**Illustration.** The process of frequency modulation (FM) can be made more illustrative if we consider numerical values. Fig. 16.13 shows the FM signal having carrier frequency  $f_c = 100 \text{ kHz}$ . Note that FM signal has constant amplitude but varying frequencies above and below the carrier frequency of  $100 \text{ kHz}$  ( $=f_c$ ). For this reason,  $f_c$  ( $= 100 \text{ kHz}$ ) is called **centre frequency**. The changes in the carrier frequency are produced by the audio-modulating signal. The amount of change in frequency from  $f_c$  ( $= 100 \text{ kHz}$ ) or **frequency deviation** depends upon the amplitude of the audio-modulating signal. The frequency deviation increases with the increase in the modulating signal and vice-versa. Thus the peak audio voltage will produce maximum frequency deviation. Referring to Fig. 16.13, the centre frequency is  $100 \text{ kHz}$  and the maximum frequency deviation is  $30 \text{ kHz}$ . The following points about frequency modulation (FM) may be noted carefully :

- The frequency deviation of FM signal depends on the amplitude of the modulating signal.
- The centre frequency is the frequency without modulation or when the modulating voltage is zero.
- The audio frequency (*i.e.* frequency of modulating signal) does not determine frequency deviation.

**Advantages :** The following are the advantages of FM over AM :

- (i) It gives noiseless reception. As discussed before, noise is a form of amplitude variations and a FM receiver will reject such signals.
- (ii) The operating range is quite large.
- (iii) It gives high-fidelity reception.
- (iv) The efficiency of transmission is very high.

### 16.12 Theory of Frequency Modulation (FM)

In frequency modulation (FM), the amplitude of the carrier is kept constant but the frequency  $f_c$  of the carrier is varied by the modulating signal. The carrier frequency  $f_c$  varies at the rate of the \*signal frequency  $f_s$ ; the frequency deviation being proportional to the instantaneous amplitude of the modulating signal. Note that maximum frequency deviation is  $(f_{c(max)} - f_c)$  and occurs at the peak voltage of the modulating signal. Suppose we modulate a 100 MHz carrier by 1V, 1 kHz modulating signal and the maximum frequency deviation is 25 kHz. This means that the carrier frequency will vary sinusoidally between  $(100 + 0.025)$  MHz and  $(100 - 0.025)$  MHz at the rate of 1000 times per second. If the amplitude of the modulating signal is increased to 2V, then the maximum frequency deviation will be 50 kHz and the carrier frequency will vary between  $(100 + 0.05)$  MHz and  $(100 - 0.05)$  MHz at the rate of 1000 times per second.

Suppose a modulating sine-wave signal  $e_s (= E_s \cos \omega_s t)$  is used to vary the carrier frequency  $f_c$ . Let the change in carrier frequency be  $ke_s$  where  $k$  is a constant known as the **frequency deviation constant**. The instantaneous carrier frequency  $f_i$  is given by ;

$$f_i = f_c + k e_s$$

$$= f_c + k E_s \cos \omega_s t$$

A graph of  $f_i$  versus time is shown in Fig. 16.14. It is important to note that it is frequency-time curve and not amplitude-time curve. The factor  $k E_s$  represents the maximum frequency deviation and is denoted by  $\Delta f$  i.e.

Max. frequency deviation,  $\Delta f = ** k E_s$

$\therefore f_i = f_c + \Delta f \cos \omega_s t$

**Equation of FM wave.** In frequency modulation, the carrier frequency is varied sinusoidally at signal frequency. The instantaneous deviation in frequency from the carrier is proportional to the instantaneous amplitude of the modulating signal. Thus the instantaneous angular frequency of FM is given by ;

$$\omega_i = \omega_c + \Delta \omega_c \cos \omega_s t$$

Total phase angle  $\theta = \omega t$  so that if  $\omega$  is variable, then,

$$\theta = \int_0^t \omega_i dt$$

$$= \int_0^t (\omega_c + \Delta \omega_c \cos \omega_s t) dt$$

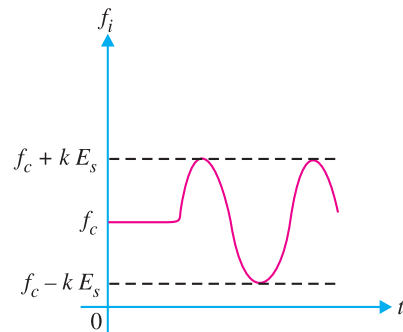

Fig. 16.14

\* Note this point. It means that modulating frequency is the rate of frequency of deviations in the RF carrier. For example, all signals having the same amplitude will deviate the carrier frequency by the same amount, say 50 kHz, no matter what their frequencies. On similar lines, all signals of the same frequency, say, 3 kHz, will deviate the carrier at the same rate of 3000 times per second, no matter what their individual amplitudes.

\*\* Note that  $k$  is in kHz or MHz per volt.

## 428 ■ Principles of Electronics

$$\therefore \theta = \omega_c t + \frac{\Delta\omega_c}{\omega_s} \sin \omega_s t$$

The term  $\frac{\Delta\omega_c}{\omega_s}$  is called **modulation index**  $m_f$ .

$$\therefore \theta = \omega_c t + m_f \sin \omega_s t$$

The instantaneous value of FM voltage wave is given by ;

$$e = E_c \cos \theta$$

$$\text{or} \quad e = E_c \cos (\omega_c t + m_f \sin \omega_s t) \quad \dots(i)$$

Exp. (i) is the general voltage equation of a FM wave. The following points may be noted carefully :

(i) The modulation index  $m_f$  is the ratio of maximum frequency deviation ( $\Delta f$ ) to the frequency ( $=f_s$ ) of the modulating signal *i.e.*

$$\text{Modulation index, } m_f = \frac{\Delta\omega_c}{\omega_s} = \frac{f_{c(\max)} - f_c}{f_s} = \frac{\Delta f}{f_s}$$

(ii) Unlike amplitude modulation, the modulation index ( $m_f$ ) for frequency modulation can be greater than unity.

**Frequency Spectrum.** It requires advanced mathematics to derive the spectrum of FM wave. We will give only the results without derivation. If  $f_c$  and  $f_s$  are the carrier and signal frequencies respectively, then FM spectrum will have the following frequencies :

$$f_c ; f_c \pm f_s ; f_c \pm 2f_s ; f_c \pm 3f_s \quad \text{and so on.}$$

Note that  $f_c + f_s, f_c + 2f_s, f_c + 3f_s, \dots$  are the upper sideband frequencies while  $f_c - f_s, f_c - 2f_s, f_c - 3f_s, \dots$  are the lower sideband frequencies.

**Example 16.16.** A frequency modulated voltage wave is given by the equation :

$$e = 12 \cos (6 \times 10^8 t + 5 \sin 1250 t)$$

Find (i) carrier frequency (ii) signal frequency (iii) modulation index (iv) maximum frequency deviation (v) power dissipated by the FM wave in 10-ohm resistor.

**Solution.** The given FM voltage wave is

$$e = 12 \cos (6 \times 10^8 t + 5 \sin 1250 t) \quad \dots(i)$$

The equation of standard FM voltage wave is

$$e = E_c \cos (\omega_c t + m_f \sin \omega_s t) \quad \dots(ii)$$

Comparing eqs. (i) and (ii), we have,

$$(i) \quad \text{Carrier frequency, } f_c = \frac{\omega_c}{2\pi} = \frac{6 \times 10^8}{2\pi} = \mathbf{95.5 \times 10^6 \text{ Hz}}$$

$$(ii) \quad \text{Signal frequency, } f_s = \frac{\omega_s}{2\pi} = \frac{1250}{2\pi} = \mathbf{199 \text{ Hz}}$$

$$(iii) \quad \text{Modulation index, } m_f = \mathbf{5}$$

$$(iv) \quad \text{Max. frequency deviation, } \Delta f = m_f \times f_s = 5 \times 199 = \mathbf{995 \text{ Hz}}$$

$$(v) \quad \text{Power dissipated, } P = \frac{E_{r.m.s.}^2}{R} = \frac{(12/\sqrt{2})^2}{10} = \mathbf{7.2 \text{ W}}$$

**Example 16.17.** A 25 MHz carrier is modulated by a 400 Hz audio sine wave. If the carrier voltage is 4V and the maximum frequency deviation is 10 kHz, write down the voltage equation of the FM wave.

**Solution.** The voltage equation of the FM wave is

$$e = E_c \cos (\omega_c t + m_f \sin \omega_s t)$$

Here  $\omega_c = 2\pi f_c = 2\pi \times 25 \times 10^6 = 1.57 \times 10^8 \text{ rad/s}$   
 $\omega_s = 2\pi f_s = 2\pi \times 400 = 2513 \text{ rad/s}$   
 $m_f = \frac{\Delta f}{f_s} = \frac{10 \text{ kHz}}{400 \text{ Hz}} = \frac{10 \times 10^3 \text{ Hz}}{400 \text{ Hz}} = 25$   
 $\therefore e = 4 \cos(1.57 \times 10^8 t + 25 \sin 2513t)$  **Ans.**

**Example 16.18.** Calculate the modulation index for an FM wave where the maximum frequency deviation is 50 kHz and the modulating frequency is 5 kHz.

**Solution.**

Max. frequency deviation,  $\Delta f = 50 \text{ kHz}$

Modulating frequency,  $f_s = 5 \text{ kHz}$

$\therefore$  Modulation index,  $m_f = \frac{\Delta f}{f_s} = \frac{50 \text{ kHz}}{5 \text{ kHz}} = 10$

**Example 16.19.** The carrier frequency in an FM modulator is 1000 kHz. If the modulating frequency is 15 kHz, what are the first three upper sideband and lower sideband frequencies?

**Solution.**

Carrier frequency,  $f_c = 1000 \text{ kHz}$

Modulating frequency,  $f_s = 15 \text{ kHz}$

*Upper sideband frequencies*

$f_c + f_s$	;	$f_c + 2f_s$	;	$f_c + 3f_s$
1000 + 15	;	1000 + 2 × 15	;	1000 + 3 × 15
<b>1015 kHz</b>	;	<b>1030 kHz</b>	;	<b>1045 kHz</b>

*Lower sideband frequencies*

$f_c - f_s$	;	$f_c - 2f_s$	;	$f_c - 3f_s$
1000 - 15	;	1000 - 2 × 15	;	1000 - 3 × 15
<b>985 kHz</b>	;	<b>970 kHz</b>	;	<b>955 kHz</b>

**Example 16.20.** The carrier and modulating frequencies of an FM transmitter are 100 MHz and 15 kHz respectively. If the maximum frequency deviation is 75 kHz, find the bandwidth of FM signal.

**Solution.** To calculate the exact bandwidth of an FM signal, it requires the use of advanced mathematics (Bessel functions) which is beyond the level of this book. However, the bandwidth of an FM signal is approximately given by ;

Bandwidth,  $BW = 2 [\Delta f + f_s] = 2 [75 + 15] = 180 \text{ kHz}$

**Example 16.21.** In a frequency modulated wave, frequency deviation constant is 75 kHz/volt and the signal amplitude is 2V. Find the maximum frequency deviation.

**Solution.**

Frequency deviation constant,  $k = 75 \text{ kHz/V}$

Amplitude of signal,  $E_s = 2 \text{ V}$

$\therefore$  Max. frequency deviation,  $\Delta f = k E_s = 75 \times 2 = 150 \text{ kHz}$

**Example 16.22.** In an FM system, when the audio frequency (AF) is 500 Hz and the AF voltage is 2.4V, the frequency deviation is 4.8 kHz. If the AF voltage is now increased to 7.2V, what is the new frequency deviation? If the AF voltage is raised to 10V while the AF is dropped to 200 Hz, what is the deviation? Find the modulation index in each case.

## 430 ■ Principles of Electronics

### Solution.

We know that :

$$\text{Frequency deviation, } \Delta f_1 = k E_s$$

$$\therefore \text{ Frequency deviation constant, } k = \frac{\Delta f_1}{E_s} = \frac{4.8}{2.4} = 2 \text{ kHz/V}$$

$$\text{For } E_s = 7.2\text{V, } \Delta f_2 = 2 \times 7.2 = \mathbf{14.4 \text{ kHz}}$$

$$\text{For } E_s = 10\text{V, } \Delta f_3 = 2 \times 10 = \mathbf{20 \text{ kHz}}$$

The answer of **20 kHz** shows that deviation is independent of modulating frequency.

The modulation indices in the three cases are :

$$m_{f1} = \frac{\Delta f_1}{f_{s1}} = \frac{4.8}{0.5} = \mathbf{9.6}$$

$$m_{f2} = \frac{\Delta f_2}{f_{s1}} = \frac{14.4}{0.5} = \mathbf{28.8}$$

$$m_{f3} = \frac{\Delta f_3}{f_{s2}} = \frac{20}{0.2} = \mathbf{100}$$

It is important to note that for calculating modulation index, the modulating frequency change had to be taken into account in the third case.

## 16.13 Comparison of FM and AM

The comparison of FM and AM is given in the table below.

S. No	FM	AM
1.	The amplitude of carrier remains constant with modulation.	The amplitude of carrier changes with modulation.
2.	The carrier frequency changes with modulation.	The carrier frequency remains constant with modulation.
3.	The carrier frequency changes according to the strength of the modulating signal.	The carrier amplitude changes according to the strength of the modulating signal.
4.	The value of modulation index ( $m_f$ ) can be more than 1.	The value of modulation factor ( $m$ ) cannot be more than 1 for distortionless AM signal.

## 16.14 Demodulation

The process of recovering the audio signal from the modulated wave is known as **demodulation or detection**.

At the broadcasting station, modulation is done to transmit the audio signal over larger distances to a receiver. When the modulated wave is picked up by the radio receiver, it is necessary to recover the audio signal from it. This process is accomplished in the radio receiver and is called demodulation.

**Necessity of demodulation.** It was noted previously that amplitude modulated wave consists of carrier and sideband frequencies. The audio signal is contained in the sideband frequencies which are radio frequencies. If the modulated wave after amplification is directly fed to the speaker as shown in Fig. 16.15, no sound will be heard. It is because diaphragm of the speaker is not at all able to respond to such high frequencies. Before the diaphragm is able to move in one direction, the rapid reversal of current tends to move it in the opposite direction i.e. diaphragm will not move at all. Consequently, no sound will be heard.

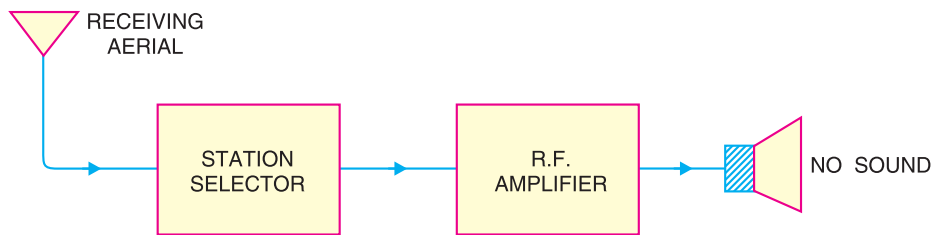

Fig. 16.15

From the above discussion, it follows that audio signal must be separated from the carrier at a suitable stage in the receiver. The recovered audio signal is then amplified and fed to the speaker for conversion into sound.

### 16.15 Essentials in Demodulation

In order that a modulated wave is audible, it is necessary to change the nature of modulated wave. This is accomplished by a circuit called *detector*. A detector circuit performs the following two functions :

(i) *It rectifies the modulated wave i.e.* negative half of the modulated wave is eliminated. As shown in Fig. 16.16 (i), a modulated wave has positive and negative halves exactly equal. Therefore, average current is zero and speaker cannot respond. If the negative half of this modulated wave is eliminated as shown in Fig. 16.16 (ii), the average value of this wave will not be zero since the resultant pulses are now all in one direction. The average value is shown by the dotted line in Fig. 16.16 (ii). Therefore, the diaphragm will have definite displacement corresponding to the average value of the wave. It may be seen that shape of the average wave is similar to that of the modulation envelope. As the signal is of the same shape as the envelope, therefore, average wave shape is of the same form as the signal.

(ii) *It separates the audio signal from the carrier.* The rectified modulated wave contains the audio signal and the carrier. It is desired to recover the audio signal. This is achieved by a filter circuit which removes the carrier frequency and allows the audio signal to reach the load *i.e.* speaker.

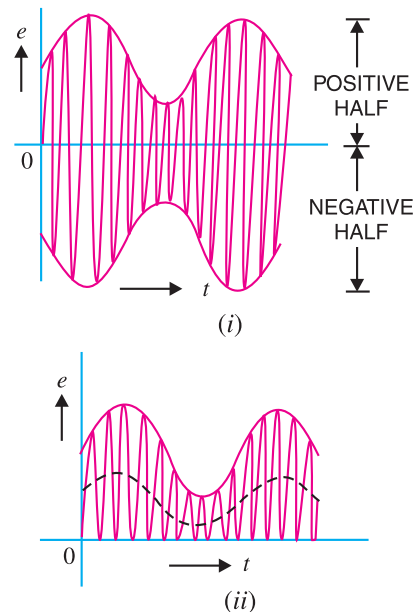

Fig. 16.16

### 16.16 A.M. Diode Detector

Fig. 16.17 shows a simple detector circuit employing vacuum diode and filter circuit. The modulated wave of desired frequency is selected by the parallel tuned circuit  $L_1C_1$  and is applied to the vacuum diode. During the positive half-cycles of modulated wave, the diode conducts while during negative half-cycles, it does not. The result of this rectifying action is that output of the diode consists of positive half-cycles of modulated wave as shown.

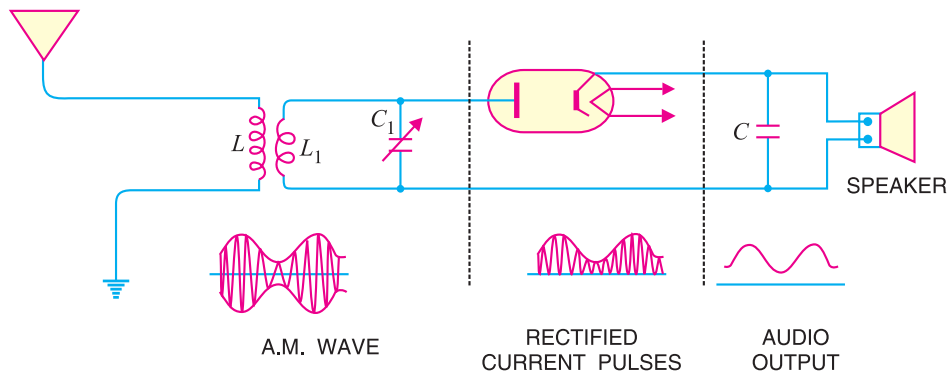

Fig. 16.17

The rectified modulated wave contains radio frequency and the signal and cannot be fed to the speaker for sound reproduction. If done so, no sound will be heard due to the inertia of speaker diaphragm. The r.f. component is filtered by the capacitor  $C$  shunted across the speaker. The value of this capacitor is sufficiently large to present low reactance to the r.f. component while presenting a relatively high reactance to the audio signal. The result is that the r.f. component is bypassed by the capacitor  $C$  and the signal is passed on to the speaker for sound reproduction.

**Note.** If vacuum diode is replaced by a crystal diode, the circuit becomes crystal diode detector.

### 16.17 A.M. Radio Receivers

A radio receiver is a device which reproduces the modulated or radio waves into sound waves. In India, only amplitude modulation is used for radio transmission and reception. Therefore, such radio

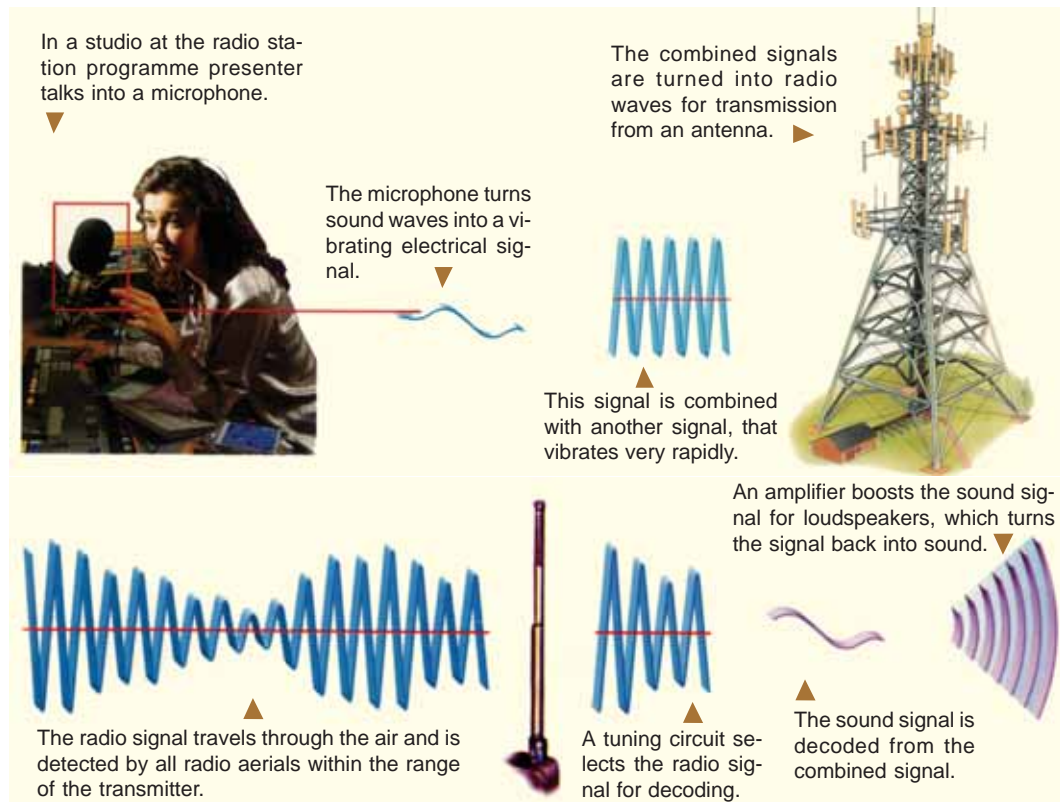



receivers are called A.M. radio receivers. In order to reproduce the A.M. wave into sound waves, every radio receiver must perform the following functions :

- (i) The receiving aerial must intercept a portion of the passing radio waves.
- (ii) The radio receiver must select the desired radio wave from a number of radio waves intercepted by the receiving aerial. For this purpose, tuned parallel  $LC$  circuits must be used. These circuits will select only that radio frequency which is in resonant with them.
- (iii) The selected radio wave must be amplified by the tuned frequency amplifiers.
- (iv) The audio signal must be recovered from the amplified radio wave.
- (v) The audio signal must be amplified by suitable number of audio-amplifiers.
- (vi) The amplified audio signal should be fed to the speaker for sound reproduction.

### 16.18 Types of A.M. Radio Receivers

A.M. radio receivers can be broadly classified into two types viz., *straight radio receiver* and *superhetrodyne radio receiver*. The former was used in the early days of radio communication. However at present, all radio receivers are of superhetrodyne type.

**1. Straight radio receiver.** Fig. 16.18 shows the block diagram of a straight radio receiver. The aerial is receiving radio waves from different broadcasting stations. The desired radio wave is selected by the R.F. amplifier which employs a tuned parallel circuit. The selected radio wave is amplified by the tuned r.f. amplifiers. The amplified radio wave is fed to the detector circuit. This circuit extracts the audio signal from the radio wave. The output of the detector is the audio signal which is amplified by one or more stages of audio-amplification. The amplified audio signal is fed to the speaker for sound reproduction.

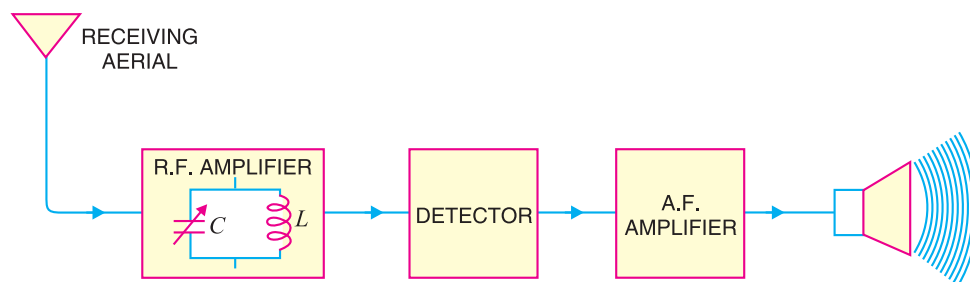

Fig. 16.18

#### Limitations.

(i) In straight radio receivers, tuned circuits are used. As it is necessary to change the value of variable capacitors (gang capacitors) for tuning to the desired station, therefore, there is a considerable variation of  $Q$  between the closed and open positions of the variable capacitors. This changes the sensitivity and selectivity of the radio receivers.

(ii) There is too much interference of adjacent stations.

**2. Superhetrodyne receiver.** The shortcomings of straight radio receiver were overcome by the invention of superhetrodyne receiver by Major Edwin H. Armstrong during the First World War. At present, all modern receivers utilise the superhetrodyne circuit. In this type of radio receiver, the selected radio frequency is converted to a fixed lower value, called *intermediate frequency (IF)*. This is achieved by a special electronic circuit called *mixer circuit*. There is a local oscillator in the radio receiver itself. This oscillator produces high frequency waves. The selected radio frequency is mixed with the high frequency wave by the mixer circuit. In this process, beats are produced and the *mixer produces a frequency equal to the difference between local oscillator and radio wave fre-*

## 434 ■ Principles of Electronics

**quency.** As explained later, the circuit is so designed that oscillator always produces a frequency 455 kHz above the selected radio frequency. Therefore, the mixer will always produce an intermediate frequency of 455 kHz regardless of the station to which the receiver is tuned. For instance, if 600 kHz station is tuned, then local oscillator will produce a frequency of 1055 kHz. Consequently, the output from the mixer will have a frequency of 455 kHz. Fig. 16.19 shows the superhetrodyne principle with a block diagram. The selected radio frequency  $f_1$  is mixed with a frequency  $f_2$  from a local oscillator. The output from the mixer is a difference (*i.e.*  $f_2 - f_1$ ) and is always 455 kHz regardless of the station to which the receiver is tuned.

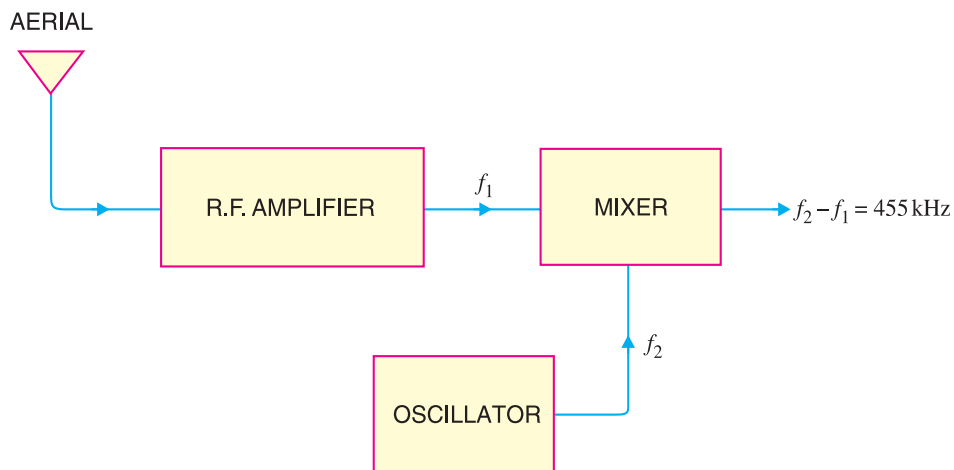

Fig. 16.19

The production of fixed intermediate frequency (455 kHz) is the salient feature of superhetrodyne circuit. At this fixed intermediate frequency, the amplifier circuits operate with maximum stability, selectivity and sensitivity. As the conversion of incoming radio frequency to the intermediate frequency is achieved by *heterodyning* or beating the local oscillator against radio frequency, therefore, this circuit is called \*superhetrodyne circuit.

### 16.19 Stages of Superhetrodyne Radio Receiver

Fig. 16.20 shows the block diagram of a superhetrodyne receiver. It may be seen that R.F. amplifier stage, mixer stage and oscillator stage use tuned parallel circuits with variable capacitors. These capacitors are ganged together as shown by the dotted interconnecting lines. The rotation of the common shaft simultaneously changes the capacitance of these tuned circuits.

**(i) R.F. amplifier stage.** The R.F. amplifier stage uses a tuned parallel circuit  $L_1C_1$  with a variable capacitor  $C_1$ . The radio waves from various broadcasting stations are intercepted by the receiving aerial and are coupled to this stage. This stage selects the desired radio wave and raises the strength of the wave to the desired level.

**(ii) Mixer stage.** The amplified output of R.F. amplifier is fed to the mixer stage where it is combined with the output of a local oscillator. The two frequencies beat together and produce an intermediate frequency (*IF*). The intermediate frequency is the difference between oscillator frequency and radio frequency *i.e.*

$$I.F. = \text{Oscillator frequency} - \text{Radio frequency}$$

\* In a super-hetrodyne receiver, the hetrodyne principle is used to produce an intermediate frequency which is higher than that can be heard *i.e.*, supersonic. Superhetrodyne is short for supersonic hetrodyne.

The IF is always 455 kHz regardless of the frequency to which the receiver is tuned. The reason why the mixer will always produce 455 kHz frequency above the radio frequency is that oscillator always produces a frequency 455 kHz \*above the selected radio frequency. This is achieved by making  $C_3$  smaller than  $C_1$  and  $C_2$ . By making  $C_3$  smaller, oscillator will tune to a higher frequency. In practice, capacitance of  $C_3$  is designed to tune the oscillator to a frequency higher than radio wave frequency by 455 kHz. This frequency difference (*i.e.* 455 kHz) will always be maintained because when  $C_1$  and  $C_2$  are varied,  $C_3$  will also vary proportionally. It may be noted that in mixer stage, the carrier frequency is reduced. The IF still contains the audio signal.

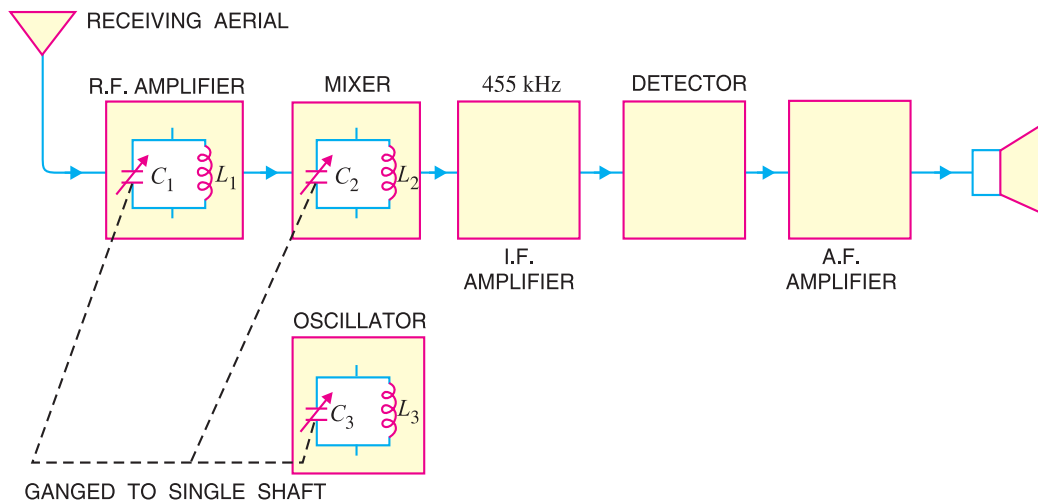

Fig. 16.20

**(iii) I.F. amplifier stage.** The output of mixer is always 455 kHz and is fed to fixed tuned I.F. amplifiers. These amplifiers are tuned to one frequency (*i.e.* 455 kHz) and render nice amplification.

**(iv) Detector stage.** The output from the last IF amplifier stage is coupled to the input of the detector stage. Here, the audio signal is extracted from the IF output. Usually, diode detector circuit is used because of its low distortion and excellent audio fidelity.

**(v) A.F. amplifier stage.** The audio signal output of detector stage is fed to a multistage audio amplifier. Here, the signal is amplified until it is sufficiently strong to drive the speaker. The speaker converts the audio signal into sound waves corresponding to the original sound at the broadcasting station.



Superhetrodyne Receiver

## 16.20 Advantages of Superhetrodyne Circuit

The basic principle involved in superheterodyne circuit is to obtain a fixed intermediate frequency with the help of a mixer circuit and local oscillator. The superheterodyne principle has the following advantages :

- \* The reason that the oscillator is designed to produce a frequency 455 kHz above and not below the selected frequency is as follows. A radio receiver is required to tune over 550 to 1600 kHz frequency. To provide IF of 455 kHz, the oscillator frequency must vary from 1005 to 2055 kHz. If the oscillator is designed to produce a frequency 455 kHz below the selected frequency (of course IF will be still 455 kHz), then the frequency range of the oscillator will have to be 95 to 1145 kHz. This frequency ratio is too high to be covered in a single band.

## 436 ■ Principles of Electronics

(i) **High r.f. amplification.** The superhetrodyne principle makes it possible to produce an intermediate frequency (*i.e.* 455 kHz) which is much less than the radio frequency. R.F. amplification at low frequencies is more stable since feedback through stray and interelectrode capacitance is reduced.

(ii) **Improved selectivity.** Losses in the tuned circuits are lower at intermediate frequency. Therefore, the quality factor  $Q$  of the tuned circuits is increased. This makes the amplifier circuits to operate with maximum selectivity.

(iii) **Lower cost.** In a superhetrodyne circuit, a fixed intermediate frequency is obtained regardless of the radio wave selected. This permits the use of fixed R.F. amplifiers. The superhetrodyne receiver is thus cheaper than other radio receivers.

### 16.21 FM Receiver

The FM receiver is more complicated and, therefore, more expensive than the normal AM receiver. As we shall see, an FM receiver also uses superheterodyne principle. The FM broadcast signals lie in the frequency range between 88 MHz and 108 MHz. The IF (intermediate frequency) of an FM receiver is 10.7 MHz—much \*higher than the IF value of 455 kHz in AM receivers. Fig. 16.21 shows the block diagram of an FM receiver. In the interest of understanding, we shall discuss the various sections of the FM receiver.

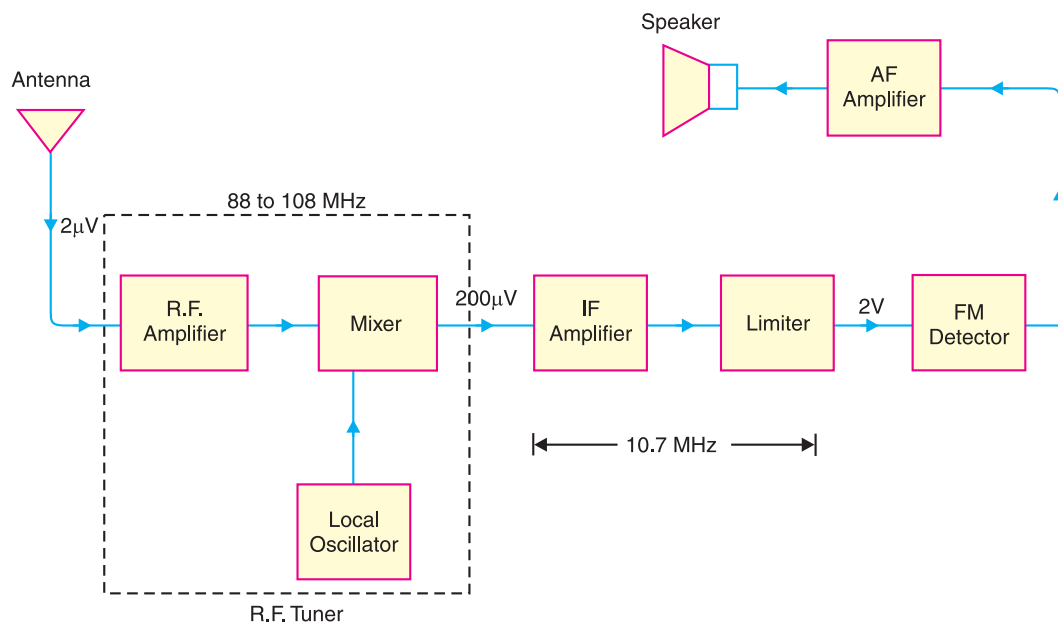

Fig. 16.21

- R.F. Tuner.** The FM signals are in the frequency range of 88 to 108 MHz. The weak FM signal (say  $2\mu\text{V}$ ) is picked up by the antenna and is fed to the R.F. tuner. The R.F. tuner consists of (i) R.F. amplifier (ii) Mixer and (iii) local oscillator. The R.F. amplifier amplifies the selected FM signal (to  $200\mu\text{V}$  in the present case). The output from the RF amplifier is fed to the mixer stage where it is combined with the output signal from a local oscillator. The two frequencies beat together and produce an intermediate frequency (IF). The intermediate frequency (IF) is equal to the difference between oscillator frequency and the RF frequency.

\* It is because the RF carrier frequencies for FM radio broadcasting are in the 88 to 108 MHz band.

The IF is always 10.7 MHz (Recall IF in AM receiver is 455 kHz) regardless of the frequency to which the FM receiver is tuned.

**2. IF Amplifier Stage.** The output signal from the mixer always has a frequency of 10.7 MHz and is fed to the IF amplifiers. Since IF amplifiers are tuned to IF (= 10.7 MHz), they render nice amplification. Note that bandwidth of IF amplifiers is about 200 kHz or 0.2 MHz. The IF gain is very large (assumed 10,000 in this case) so that output is 2V.

**3. Limiter Stage.** The output from IF stage is fed to the limiter. This circuit is an IF amplifier tuned to 10.7 MHz but its main function is to remove AM interference from the FM signal. Fig. 16.22 shows how the limiter removes AM interference from the FM signal.

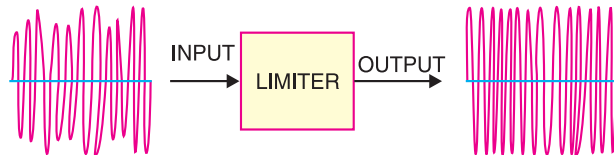

Fig. 16.22

The input is an FM signal, but it has different amplitude levels because of AM interference has been added. However, the limiter circuit keeps the output level constant for different input levels.

**4. FM Detector.** After the removal of amplitude modulation from the FM signal by the limiter, the IF signal drives the input of the FM detector. An FM detector is a circuit that converts frequency variations to amplitude variations. The FM detector is also called a *discriminator* because it can distinguish between different frequencies in the input to provide different output voltages. The resultant amplitude modulated signal is then rectified and amplified for feeding to speaker for sound reproduction.

### 16.22 Difference Between FM and AM Receivers

Both FM and AM receivers employ superheterodyne principle. However, the following are the points of differences between the two types of receivers :

- (i) An FM receiver has two additional stages viz. limiter and discriminator, which are quite different from an AM receiver.
- (ii) FM broadcast signals lie in the frequency range between 88 and 108 MHz whereas AM broadcast signals lie in the frequency range from 540 kHz to 1600 kHz.
- (iii) FM receivers are free from interference and this means that much weaker signals can be successfully handled.
- (iv) FM bandwidth is about 200 kHz compared to 10 kHz bandwidth for AM.
- (v) The IF for FM receivers is 10.7 MHz whereas IF for AM receivers is 455 kHz.

### MULTIPLE-CHOICE QUESTIONS

1. Modulation is done in .....
  - (i) transmitter
  - (ii) radio receiver
  - (iii) between transmitter and radio receiver
  - (iv) none of the above
2. In a transmitter, ..... oscillator is used.
  - (i) Hartley
  - (ii) RC phase-shift
  - (iii) Wien-bridge
  - (iv) crystal
3. In India, ..... modulation is used for radio transmission.
  - (i) frequency
  - (ii) amplitude
  - (iii) phase
  - (iv) none of the above
4. In an AM wave, useful power is carried by .....
  - (i) carrier
  - (ii) sidebands
  - (iii) both sidebands and carrier
  - (iv) none of the above
5. In amplitude modulation, bandwidth is ..... the audio signal frequency.

**438 ■ Principles of Electronics**

- (i) thrice (ii) four times  
(iii) twice (iv) none of the above
6. In amplitude modulation, the ..... of carrier is varied according to the strength of the signal.  
(i) amplitude (ii) frequency  
(iii) phase (iv) none of the above
7. Overmodulation (amplitude) occurs when signal amplitude is ..... carrier amplitude.  
(i) equal to (ii) greater than  
(iii) less than (iv) none of the above
8. In an AM wave, the majority of the power is in .....  
(i) lower sideband  
(ii) upper sideband  
(iii) carrier  
(iv) none of the above
9. At 100 % modulation, the power in each sideband is ..... of that of carrier.  
(i) 50 % (ii) 40 %  
(iii) 60 % (iv) 25 %
10. Overmodulation results in .....  
(i) weakening of the signal  
(ii) excessive carrier power  
(iii) distortion  
(iv) none of the above
11. If modulation is 100 %, then signal amplitude is ..... carrier amplitude.  
(i) equal to (ii) greater than  
(iii) less than (iv) none of the above
12. As the modulation level is increased, the carrier power .....  
(i) is increased (ii) remains the same  
(iii) is decreased (iv) none of the above
13. Demodulation is done in .....  
(i) receiving antenna  
(ii) transmitter  
(iii) radio receiver  
(iv) transmitting antenna
14. A high  $Q$  tuned circuit will permit an amplifier to have high .....  
(i) fidelity (ii) frequency range  
(iii) sensitivity (iv) selectivity
15. In radio transmission, the medium of transmission is .....  
(i) space (ii) an antenna  
(iii) cable (iv) none of the above
16. If level of modulation is increased ..... power is increased.  
(i) carrier  
(ii) sideband  
(iii) carrier as well as sideband  
(iv) none of the above
17. In TV transmission, picture signal is ..... modulated.  
(i) frequency (ii) phase  
(iii) amplitude (iv) none of the above
18. In a radio receiver, noise is generally developed at .....  
(i) IF stage (ii) receiving antenna  
(iii) audio stage (iv) RF stage
19. Man made noises are ..... variations.  
(i) amplitude  
(ii) frequency  
(iii) phase  
(iv) both phase and frequency
20. The signal voltage induced in the aerial of a radio receiver is of the order of .....  
(i)  $mV$  (ii)  $\mu V$   
(iii)  $V$  (iv) none of the above
21. Superhetrodyne principle refers to .....  
(i) using a large number of amplifier stages  
(ii) using a push-pull circuit  
(iii) obtaining lower fixed intermediate frequency  
(iv) none of the above
22. If a radio receiver amplifies all the signal frequencies equally well, it is said to have high .....  
(i) sensitivity (ii) selectivity  
(iii) distortion (iv) fidelity
23. Most of the amplification in a superhetrodyne receiver occurs at ..... stage.  
(i) IF (ii) RF amplifier  
(iii) audio amplifier (iv) detector
24. The letters AVC stand for .....  
(i) audio voltage control  
(ii) abrupt voltage control  
(iii) automatic volume control  
(iv) automatic voltage control
25. The superhetrodyne principle provides selectivity at ..... stage.  
(i) RF (ii) IF  
(iii) audio (iv) before RF
26. In superhetrodyne receiver, the input at the mixer stage is .....  
(i) IF and RF  
(ii) RF and AF

- (iii) IF and AF  
(iv) RF and local oscillator signal
27. The major advantage of FM over AM is .....
- (i) reception is less noisy  
(ii) higher carrier frequency  
(iii) smaller bandwidth  
(iv) small frequency deviation
28. When the modulating signal controls the frequency of the carrier, we get, .....
- (i) phase modulation  
(ii) amplitude modulation  
(iii) frequency modulation  
(iv) may be any one of the above
29. Modulation refers to a low-frequency signal controlling the .....
- (i) amplitude of the carrier  
(ii) frequency of the carrier  
(iii) phase of the carrier  
(iv) may be any of the above
30. The IF is 455 kHz. If the radio receiver is tuned to 855 kHz, the local oscillator frequency is .....
- (i) 455 kHz (ii) 1310 kHz  
(iii) 1500 kHz (iv) 1520 kHz
31. If  $A_{min} = 40$  and  $A_{max} = 60$ , what is the percentage modulation ?
- (i) 20 % (ii) 40 %  
(iii) 50 % (iv) 10 %
32. The function of ferrite antenna is to .....
- (i) reduce stray capacitance  
(ii) stabilise d.c. bias  
(iii) increase the  $Q$  of tuned circuit  
(iv) reduce noise
33. In a radio receiver, we generally use ..... oscillator as a local oscillator.
- (i) crystal (ii) Wien-bridge  
(iii) phase-shift (iv) Hartley
34. A 100 V carrier is made to vary between 160 V and 40 V by the signal. What is the modulation factor ?
- (i) 0.3 (ii) 0.6  
(iii) 0.5 (iv) none of the above
35. A 50 kW carrier is to be amplitude modulated to a level of 85 %. What is the carrier power after modulation ?
- (i) 50 kW (ii) 42.5 kW  
(iii) 58.8 kW (iv) 25 kW
36. In the above question, what is the power in sidebands ?
- (i) 7.8 kW (ii) 11.6 kW  
(iii) 19.06 kW (iv) 15.9 kW
37. In a superhetrodyne receiver, the difference frequency is chosen as the IF rather than the sum frequency because .....
- (i) the difference frequency is closer to oscillator frequency  
(ii) lower frequencies are easier to amplify  
(iii) only the difference frequency can be modulated  
(iv) none of the above
38. The diode detector in an AM radio receiver is usually found .....
- (i) before the first RF stage  
(ii) after the first RF stage  
(iii) after several stages of amplification  
(iv) none of the above
39. In a TRF radio receiver, the RF and detection stages are tuned to .....
- (i) radio frequency  
(ii) IF  
(iii) audio frequency  
(iv) none of the above
40. In TV transmission, sound signal is ..... modulated
- (i) amplitude (ii) frequency  
(iii) phase (iv) none of the above

**Answers to Multiple-Choice Questions**

- |           |           |           |           |           |
|-----------|-----------|-----------|-----------|-----------|
| 1. (i)    | 2. (iv)   | 3. (ii)   | 4. (ii)   | 5. (iii)  |
| 6. (i)    | 7. (ii)   | 8. (iii)  | 9. (iv)   | 10. (iii) |
| 11. (i)   | 12. (ii)  | 13. (iii) | 14. (iv)  | 15. (i)   |
| 16. (ii)  | 17. (iii) | 18. (iv)  | 19. (i)   | 20. (ii)  |
| 21. (iii) | 22. (iv)  | 23. (i)   | 24. (iii) | 25. (ii)  |
| 26. (iv)  | 27. (i)   | 28. (iii) | 29. (iv)  | 30. (ii)  |
| 31. (i)   | 32. (iii) | 33. (iv)  | 34. (ii)  | 35. (i)   |
| 36. (iii) | 37. (ii)  | 38. (iii) | 39. (i)   | 40. (ii)  |



### Chapter Review Topics

1. Explain the general principles of radio broadcasting, transmission and reception.
2. What is modulation ? Why is modulation necessary in communication system ?
3. Explain amplitude modulation. Derive the voltage equation of an AM wave.
4. What do you understand by modulation factor ? What is its significance ?
5. Draw the waveform of AM wave for the following values of modulation factor :  
(i) 0    (ii) 0.5    (iii) 1    (iv) 1.5
6. What do you understand by sideband frequencies in an AM wave ?
7. Derive an expression for the fraction of total power carried by the sidebands in amplitude modulation.
8. What are the limitations of amplitude modulation ?
9. What do you understand by frequency modulation ? Explain its advantages over amplitude modulation.
10. What is demodulation ? What are essentials in demodulation ?
11. Draw the diode detector circuit and explain its action.
12. What is superhetrodyne principle ? Explain the function of each stage of superhetrodyne receiver with the help of a block diagram.

### Problems

1. The maximum peak-to-peak voltage of an AM wave is 16 mV while the minimum peak-to-peak voltage is 8 mV. Find the percentage modulation. [60%]
2. A carrier of peak voltage 0.05 V and frequency 200 kHz is amplitude modulated by a signal of peak voltage 10 V and frequency 1 kHz. Find (i) frequencies in the output spectrum and (ii) the peak values of output components if  $m = 0.5$  and voltage gain  $A = 100$ .  
[(i) 199 kHz, 200 kHz, 201 kHz (ii) 1.25 V, 5 V, 1.25 V]
3. An AM transmitter supplies 10kW to the antenna when unmodulated. Determine the total power radiated by the transmitter when modulated to 30%. [10.45 kW]
4. A certain AM transmitter radiates 8kW with carrier unmodulated and 9kW when the carrier is modulated. Find the percentage modulation. [50%]
5. A transmitter radiates a total power of 10 kW. The carrier is modulated to a depth of 60% . Calculate (i) the power in the carrier and (ii) power in each sideband. [(i) 8.47kW (ii) 0.765kW]
6. A carrier of 100 V and 1500 kHz is modulated by 60V, 1200 Hz sinusoidal signal. Calculate modulation factor and express this as percentage. [0.6; 60%]
7. A carrier with an amplitude of 140 V is modulated by a signal with an amplitude of 80V. What is the percentage modulation ? What is the amplitude of lower sideband frequency ? [57% ; 40V]
8. A 50 kW carrier is to be modulated to a level of 85%. What is the carrier power after modulation ? What is sideband power ? [50 kW ; 19.06 kW]
9. The r.m.s. antenna current of a radio transmitter is 10 A when unmodulated, rising to 12 A when the carrier is sinusoidally modulated. What is the modulation index ? [0.94]
10. The r.m.s. antenna current of an AM transmitter increases by 15% over the unmodulated value when sinusoidal modulation is applied. Determine the modulation index. [0.8]
11. A 500 Hz modulating voltage produces a frequency deviation of 2.25 kHz. What is the modulation index ? If the amplitude of the modulation voltage is kept constant, but its frequency is raised to 6 kHz, what is the new deviation ? [4.5 ; 54 kHz]
12. When the modulating frequency in an FM system is 400 Hz and the modulation voltage is 2.4V, the modulation index is 60. Calculate the maximum deviation. What is the modulation index when the modulating frequency is reduced to 250 Hz and the modulating voltage is simultaneously raised to 3.2V ? [24 kHz ; 128]

### Discussion Questions

1. Why cannot electrical energy be radiated at low frequencies ( $< 20$  kHz) ?
2. Why is radio transmission carried at high frequencies ?
3. Why does amplitude modulation give noisy reception ?
4. Why do we always design the oscillator to produce a frequency of 455 kHz above and not below the incoming radio wave ?
5. What is the importance of modulation factor in communication system ?
6. Why is superhetrodyne principle employed in radio receivers ?
7. Why is AM and not FM employed for radio transmission in India ?
8. Why does frequency modulation give noiseless reception ?
9. Why have we selected  $IF$  as 455 kHz ?
10. What is the importance of sideband frequencies ?

Top