

3

Gas-Filled Tubes

- 3.1 Gas-Filled Tubes
- 3.2 Conduction in a Gas
- 3.3 Cold-Cathode Gas Diode
- 3.4 Characteristics of Cold-Cathode Diode
- 3.5 Applications of Glow Tubes
- 3.6 Hot-Cathode Gas Diode
- 3.7 Thyatron
- 3.8 Applications of Thyatron



INTRODUCTION

In the vacuum tubes, the electrons flow from cathode to anode in vacuum. In such tubes, extreme care is taken to produce as perfect a vacuum as possible to prevent ionisation of gases and the resulting large uncontrolled currents. It may be mentioned here that the secret of triode is the fine control of free electrons within valve by the electrostatic fields of grid and anode. If gas is present even in small amount, the electrons flowing from cathode to anode will cause ionisation of the gas. The ionised molecules would interfere with the control and make the device useless as an amplifier.

In certain applications, fine control of electrons within the valve is of less importance than the efficient handling and turning on and off of heavy currents. In such situations, some inert gases (*e.g.* argon, neon, helium) at low pressures are purposely introduced into the valve envelope. Such tubes are known as *gas-filled tubes*. The gas-filled tubes are capable of doing various jobs that vacuum tubes cannot perform and which are especially useful in industrial and control circuits. In this chapter, we shall focus our attention on some important types of gas-filled tubes with special reference to their characteristic properties.

3.1 Gas-Filled Tubes

A **gas-filled tube** is essentially a vacuum tube having a small amount of some inert gas at low pressure.

The gas pressure in a gas-filled tube usually ranges from 10 mm of Hg to 50 mm. The construction of gas-filled tubes is similar to that of vacuum tubes, except that the cathodes, grids and anodes are usually larger in order to carry heavier current. However, the characteristic properties of the two are markedly different. Firstly, a gas-filled tube can conduct much **more* current than the equivalent vacuum tube. It is because the electrons flowing from cathode to anode collide with gas molecules and ionise them *i.e.* knock out electrons from them. The additional electrons flow to the anode together with the original electrons, resulting in the increase in plate current. Secondly, a gas filled tube has far less control on the electrons in the tube than that of vacuum tube. Once the ionisation starts, the control of gas-filled tube is tremendously reduced.

Classification. Gas-filled tubes are usually classified according to the type of electron emission employed. On this basis, they may be classified into two types namely; *cold-cathode type* and *hot-cathode type*.

Cold-cathode type. In this type of gas-filled tubes, the cathode is not heated as in a vacuum tube. The ionisation of the gas is caused by the energy available from natural sources such as cosmic rays, sun rays or radioactive particles in air. These natural sources are the underlying reasons for the start of conduction in cold-cathode gas tubes. Most cold-cathode tubes are used as diodes.



Gas-filled Tube

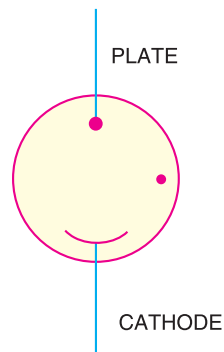

Fig. 3.1

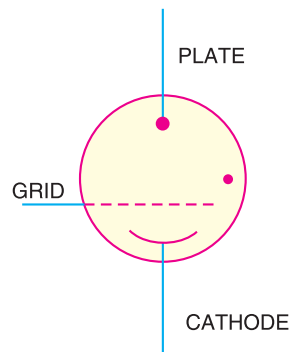

Fig. 3.2

Fig. 3.1 shows the schematic symbol for a cold-cathode gas diode, known as *glow tube*. The dot within the circle indicates the presence of gas. Fig. 3.2 shows the schematic symbol of cold-cathode gas triode, known as *grid glow tube*.

Hot-cathode type. In this type of gas-filled tubes, the cathode is heated just as in an ordinary vacuum tube. The electrons flowing from cathode to plate cause ionisation of the gas molecules. Such tubes are used as diodes, triodes and tetrodes.

* The ability of a gas-filled tube to carry large current is, of course, no recommendation in itself. A copper wire will do the same thing and with better efficiency. But a gas filled tube has one special ability which the wire does not possess ; the ability to carry current in one direction.

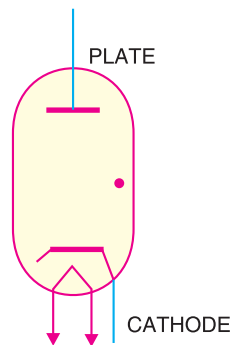

Fig. 3.3

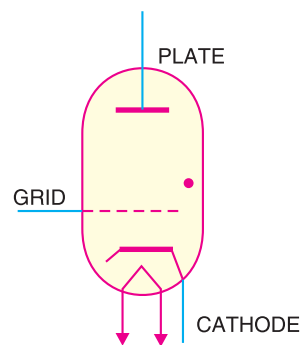

Fig. 3.4

Fig. 3.3 shows the schematic symbol of a hot-cathode gas diode, known as *photron* whereas Fig. 3.4 shows the symbol of hot-cathode gas triode, known as *thyatron*.

3.2 Conduction in a Gas

A gas under ordinary pressure is a perfect insulator and cannot conduct current. However, if the gas pressure is low, it is possible to produce a large number of free electrons in the gas by the process of ionisation and thus cause the gas to become a conductor. This is precisely what happens in gas-filled tubes. The current conduction in a gas at low pressure can be beautifully illustrated by referring to the hot-cathode gas diode shown in Fig. 3.5. The space between cathode and anode of the tube contains gas molecules. When cathode is heated, it emits a large number of electrons. These electrons form a cloud of electrons near the cathode, called **space charge**. If anode is made positive *w.r.t.* cathode, the electrons (magenta dots) from the space charge speed towards the anode and collide with gas molecules (cyan circles) in the tube.

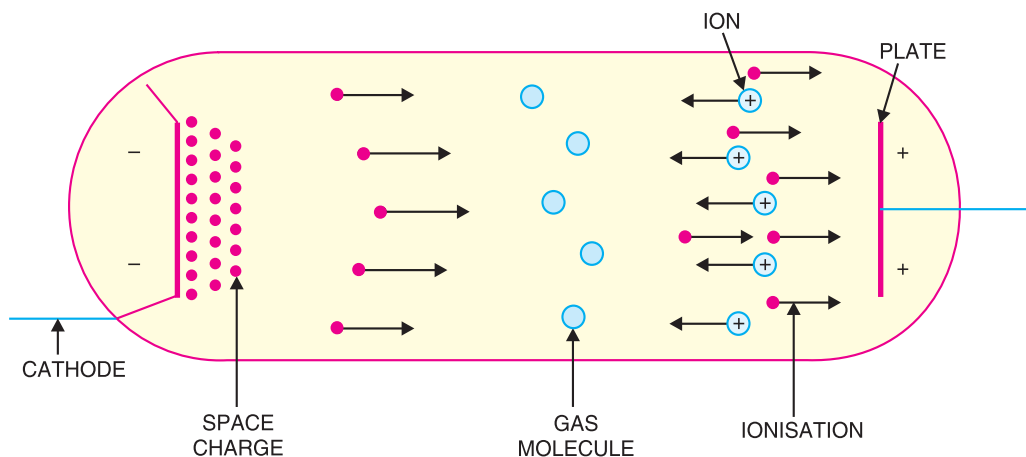

Fig. 3.5

If the anode-cathode voltage is low, the electrons do not possess the necessary energy to cause ionisation of the gas. Therefore, the plate current flow in the tube is only due to the electrons emitted by the cathode. As the anode-cathode voltage is increased, the electrons acquire more speed and energy and a point—called *ionisation voltage* is reached, where ionisation of the gas starts. The ionisation of gas produces free electrons and positive gas ions (cyan circles with +ve signs). The additional free electrons flow to the anode together with the original electrons, thus increasing plate current. However, the increase in plate current due to these added electrons is practically negligible. But the major effect is that the positive gas

ions slowly drift towards the cathode and neutralise the space charge. Consequently, the resistance of the tube decreases, resulting in large plate current. *Hence, it is due to the neutralisation of space charge by the positive gas ions that plate current in a gas tube is too much increased.*

The following points may be noted regarding the conduction in a gas at low pressure :

(i) At low anode-cathode voltage, the ionisation of the gas does not occur and the plate current is about the same as for a vacuum tube at the same anode voltage.

(ii) At some anode-cathode voltage, called ionisation voltage, ionisation of the gas takes place. The plate current increases dramatically to a large value due to the neutralisation of space charge by the positive gas ions. The ionisation voltage depends upon the type and pressure of gas in the tube.

(iii) Once ionisation has started, it is maintained at anode-cathode voltage much lower than ionisation voltage. However, minimum anode-cathode voltage, called *deionising voltage*, exists below which ionisation cannot be maintained. Under such conditions, the positive gas ions combine with electrons to form neutral gas molecules and conduction stops. Because of this switching action, a gas-filled tube can be used as an electronic switch.

3.3 Cold-Cathode Gas Diode

Fig. 3.6 shows the cut-away view of cold-cathode gas diode. It essentially consists of two electrodes, cathode and anode, mounted fairly close together in an envelope filled with some inert gas at low pressure. The anode is in the form of a thin wire whereas cathode is of cylindrical metallic surface having oxide coating. The anode is always held at positive potential *w.r.t.* cathode.

Operation. Fig. 3.7 shows a circuit that can be used to investigate the operation of cold-cathode gas diode. Electric conduction through the tube passes through three successive discharge phases *viz.* Townsend discharge, the glow discharge and the arc discharge.

(i) **Townsend discharge.** At low anode-cathode voltage, the tube conducts an extremely small current (1mA). It is because the cathode is cold and as such no source of electrons is present. However, natural sources (*e.g.* cosmic rays *etc.*) cause some ionisation of the gas, creating a few free electrons. These electrons move towards the anode to constitute a small current. This stage of conduction is known as *Townsend discharge*. In this phase of conduction, no visible light is associated.

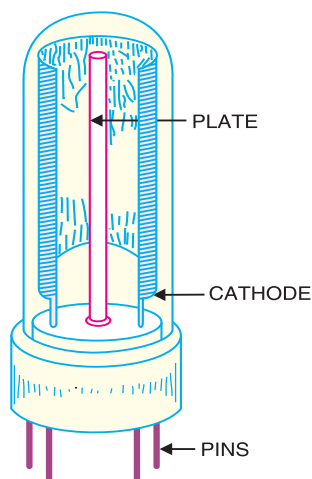

Fig. 3.6

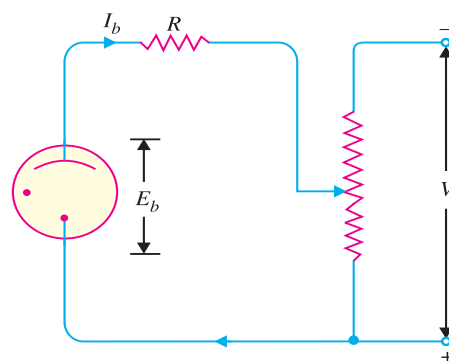

Fig. 3.7

* The volt-ampere characteristics of glow tube were first investigated by J. S. Townsend in 1901 and hence the name.

42 ■ Principles of Electronics

(ii) **Glow discharge.** As the anode-cathode voltage is increased, the electrons acquire more and more energy. At some voltage, known as *ionisation voltage*, ionisation of the gas starts and the tube current rises to a large value. The voltage across the tube drops to a low value, which remains constant regardless of the plate current. At the same time, glow is seen in the gas and on a portion of the cathode. This phase of conduction is known as *glow discharge*.

The fact that glow tube maintains constant voltage across it in the glow discharge region needs some explanation. In this region, any increase in supply voltage causes more current to flow; the drop across series resistance R increases but the voltage E_b across the tube remains constant. As the current increases, the degree of ionisation increases and the glow covers a greater part of cathode surface and hence the ionised gas path between cathode and anode has greater area of cross-section. As resistance is inversely proportional to the area of cross-section, therefore, resistance of the tube decreases. Hence, the voltage across the tube remains constant. Reverse is also true should the supply voltage decrease. Thus in the glow discharge region, the resistance of the tube changes so as to maintain constant voltage across it.

(iii) **Arc discharge.** Once the cathode glow covers the entire surface of the cathode, the x -sectional area of gas path cannot increase further. This region is known as *abnormal glow*. If the current density is further increased, the discharge becomes an arc.

3.4 Characteristics of Cold-Cathode Diode

The volt-ampere characteristic of a cold-cathode diode is shown in Fig. 3.8. At low anode-cathode voltage, the tube current is very small (1mA) and is due to the ionisation of gas molecules by the natural sources. This stage of conduction upto voltage B is known as *Townsend discharge* and is non-self maintained discharge because it requires an external source to cause ionisation. At some critical voltage such as B , the tube fires and the voltage across the tube drops (from B to C) and remains constant regardless of plate current. This is the start of second conduction and is known as *glow discharge*. In this region (C to D), voltage across the tube remains constant even if the plate current increases.

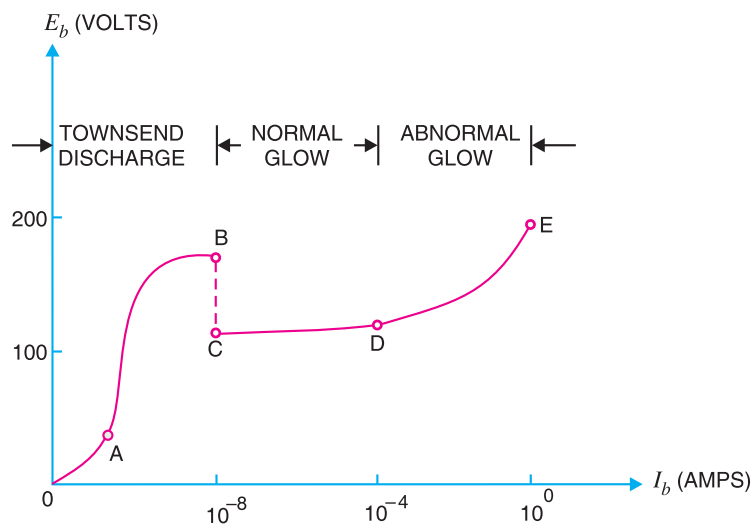

Fig. 3.8

After the glow discharge, the voltage across the tube no longer remains constant. Now, if the supply voltage is raised, not only will the circuit current increase but the voltage across the tube will start to rise again. This stage of conduction (D to E) is known as *abnormal glow*.

3.5 Applications of Glow Tubes

The outstanding characteristic of a cold-cathode gas diode (or glow tube) to maintain constant voltage across it in the glow discharge region renders it suitable for many industrial and control applications. A few of such applications are mentioned below :

(i) *As a voltage regulating tube.* A glow tube maintains constant voltage across it in the glow discharge region. This characteristic permits it to be used as a voltage regulating tube. Fig. 3.9 shows a simple circuit commonly used to maintain constant voltage across a load. The glow tube (VR tube) is connected in parallel with the load R_L across which constant voltage is desired. So long as the tube operates in the glow discharge region, it will maintain constant volt-



Voltage Regulating Tube

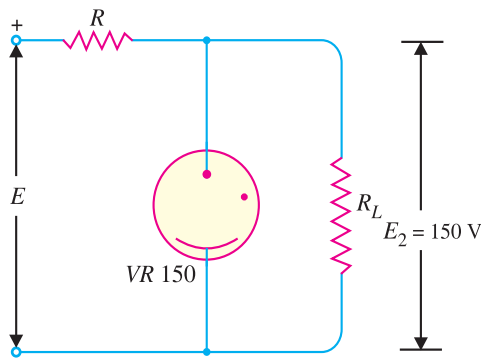

Fig. 3.9

age (= 150V) across the load. The extra voltage is dropped across the series resistance R .

(ii) *As a polarity indicator.* As the cathode is surrounded by a characteristic glow, therefore, it can be useful to indicate the polarity of a direct voltage.

(iii) *As an electronic switch,* which closes at ionisation potential, permitting a large current to flow, and opens at the deionising voltage, blocking the current flow.

(iv) *As a radio frequency field detector.* A strong radio-frequency field is capable of ionising the gas without direct connection to the tube. Therefore, the tube can indicate the presence of radio-frequency field.

3.6 Hot-Cathode Gas Diode

A hot-cathode gas diode is frequently used as a rectifier for moderate voltages because of high efficiency and better regulation. A hot-cathode gas diode consists of an oxide-coated cathode and a metallic anode enclosed in a glass envelope containing some inert gas under reduced pressure. For proper operation of the tube, anode is always held at a positive potential *w.r.t.* cathode.

Operation. Fig. 3.10 shows a circuit that can be used to investigate the operation of a hot-cathode gas diode. When cathode is heated, a large number of electrons are emitted. At low anode-cathode voltage, the tube conducts very small current. Under such conditions, the gas is not ionised and the tube acts similar to a vacuum diode — the voltage across the tube increases with plate current. This action continues until anode-cathode voltage becomes equal to the ionisation potential of the gas. Once this potential is reached, the gas begins to ionise, creating free electrons and positive gas ions. The positive gas ions move towards the cathode and tend to neutralise the space charge, thus decreasing the internal resistance of the tube. If now the plate voltage is increased, the plate current also increases due to increased degree of ionisation. This further reduces the tube resistance. As a result, increase in plate current is offset by the decrease in tube resistance *and the voltage across the tube remains constant.* Therefore, in a hot-cathode gas diode, not only the internal drop within the

44 ■ Principles of Electronics

tube is small but also it remains constant. For this reason, a gas diode has better efficiency and regulation than for a vacuum diode when used as a rectifier.

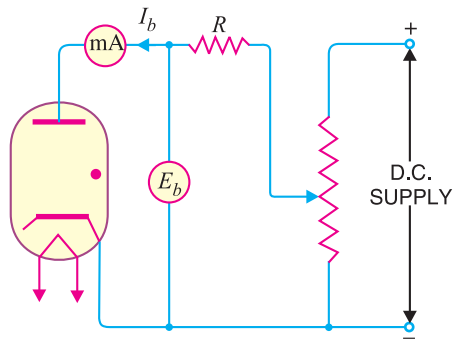

Fig. 3.10

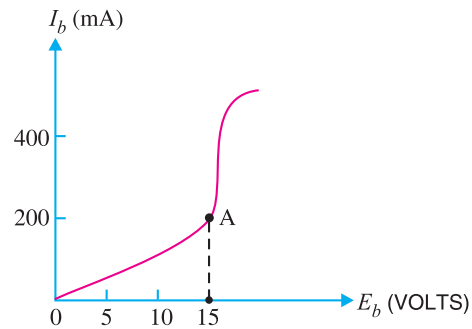

Fig. 3.11

Plate Characteristics. Fig. 3.10 shows the circuit that can be used to determine the volt-ampere (E_b/I_b) characteristics of a hot-cathode gas diode. The series resistance R is used to limit the current to reach a dangerously high value. Fig. 3.11 shows the plate characteristic of hot-cathode diode. It is clear that at first, plate current rises slowly with increase in anode-cathode voltage. However, at some voltage, known as ionisation voltage (point A), the plate current rises sharply and the voltage drop across the tube remains constant. The extra voltage is dropped across the series resistance R . Any attempt to raise the anode-cathode voltage above the ionising value is fruitless. Increasing the voltage E_b above point A results in higher plate current (I_b) and large drop across R but the voltage E_b across the tube remains constant.

3.7 Thyatron

A hot-cathode gas triode is known by the trade name *thyatron*. As discussed before, a gas diode fires at a fixed plate potential, depending upon the type of gas used and gas pressure. Very often it is necessary to control the plate potential at which the tube is to fire. Such a control is obviously impossible with a gas diode. However, if a third electrode, known as *control grid* is introduced in a gas diode, this control is possible. The tube is then known as hot-cathode gas triode or thyatron. By controlling the negative potential on the control grid, the tube can be fired at any plate potential.

Construction. Figs. 3.12 (i) and 3.12 (ii) respectively show the cut-away view and schematic symbol of a thyatron. It consists of three electrodes, namely; *cathode*, *anode* and *control grid* enclosed in a glass envelope containing some inert gas at low pressure. The cathode and anode are approximately planar. The control grid of thyatron has a special structure quite different from that of a vacuum tube. It consists of a metal cylinder surrounding the cathode with one or more perforated discs known as *grid baffles* near the centre.

Operation. When cathode is heated, it emits plenty of electrons by thermionic emission. If the control grid is made sufficiently negative, the electrons do not have the necessary energy to ionise the gas and the plate current is substantially zero. As the negative grid voltage is reduced, the electrons acquire more speed and energy. At some grid voltage, called *critical grid voltage*, ionisation of the gas occurs and the plate current rises to a large value.

*The negative grid voltage, for a given plate potential, at which ionisation of the gas starts is known as **critical grid voltage**.*

At critical grid voltage, gas ionises, creating free electrons and positive gas ions. The positive ions tend to neutralise the space charge, resulting in large plate current. In addition, these positive ions are attracted by the negative grid and neutralise the normal negative field of the grid, thereby

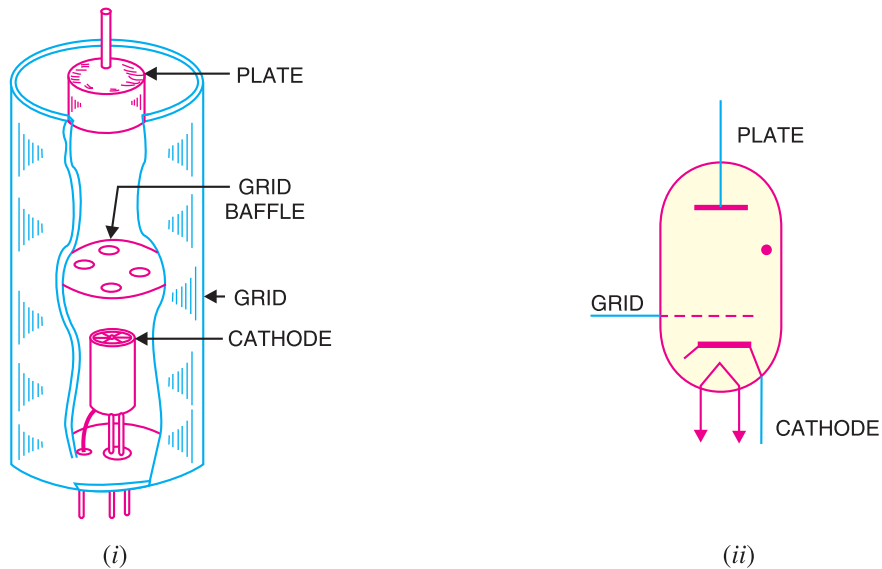

Fig. 3.12

preventing the grid from exerting any further control on the plate current of the tube. The grid now loses all control and the tube behaves as a diode. *Therefore, the function of control grid is only to start the conduction of anode current.* Once the conduction is started, the tube acts as a gas diode. It is important to realise the usefulness of control grid. We have seen that the ionisation does not start at low values of plate current. In a gas diode, it requires that the plate potential should be increased until sufficient plate current is flowing to cause ionisation. However, by adjusting the negative voltage on the grid, the desired plate current can be obtained to cause ionisation.

It may be mentioned here that once the thyatron fires, the only way to stop conduction is to reduce plate voltage to zero for a period *long enough for deionisation of the gas in the tube.

3.8 Applications of Thyatron

As the grid voltage has no control over the magnitude of plate current once the thyatron fires, therefore, it cannot be used as an amplifier like a vacuum triode. However, because of its triggering action, it is useful in switching and relay applications. Thyatrons are also used as controlled rectifiers for controlling the amount of d.c. power fed to the load. They are also used in motor control circuits.

MULTIPLE-CHOICE QUESTIONS

- A gas diode can conduct the equivalent vacuum diode for the same plate voltage.
 - less current than
 - more current than
 - same current as
 - none of the above
- A gas-filled tube has resistance before ionisation.
 - very high
 - small
 - very small
 - zero
- The PIV of a hot cathode gas diode is the equivalent vacuum diode.
 - the same as that of
 - more than that of
 - less than that of
 - none of the above

* 100 to 1000 μsec .

46 ■ Principles of Electronics

4. The anode-to-cathode potential of a gas-filled tube at which gas deionises and stops conduction is calledpotential.
 - (i) extinction
 - (ii) striking
 - (iii) ionising
 - (iv) none of the above
5. A thyatron can be used as
 - (i) an oscillator
 - (ii) an amplifier
 - (iii) a controlled switch
 - (iv) none of the above
6. The internal resistance of a gas-filled tube is that of a vacuum tube.
 - (i) the same as
 - (ii) more than
 - (iii) less than
 - (iv) none of the above
7. A cold cathode tube is generally used as a
 - (i) diode
 - (ii) triode
 - (iii) tetrode
 - (iv) pentode
8. Conduction in a cold cathode tube is started by
 - (i) thermionic emission
 - (ii) secondary emission
 - (iii) natural sources
 - (iv) none of the above
9. The cathode heating time of thermionic gas diode is that of a vacuum diode.
 - (i) the same as
 - (ii) much more than
 - (iii) much less than
 - (iv) none of the above
10. The solid state equivalent of thyatron is
 - (i) FET
 - (ii) transistor
 - (iii) SCR
 - (iv) crystal diode
11. The solid state equivalent of cold cathode diode is
 - (i) zener diode
 - (ii) crystal diode
 - (iii) LED
 - (iv) transistor
12. The noise in a gas-filled tube is that in a vacuum tube.
 - (i) the same as
 - (ii) more than
 - (iii) less than
 - (iv) none of the above
13. The ionisation potential in a gas diode depends upon
 - (i) plate current
 - (ii) cathode construction
 - (iii) size of the tube
 - (iv) type and pressure of gas
14. If the gas pressure in a gas-filled diode is increased, its PIV rating
 - (i) remains the same
 - (ii) is increased
 - (iii) is decreased
 - (iv) none of the above
15. Once a thyatron is fired, its control grid over the plate current.
 - (i) loses all control
 - (ii) exercises fine control
 - (iii) exercises rough control
 - (iv) none of the above
16. To stop conduction in a thyatron, the voltage should be reduced to zero.
 - (i) grid
 - (ii) plate
 - (iii) filament
 - (iv) none of the above
17. Ionisation of cold cathode diode takes place at plate potential compared to hot cathode gas diode.
 - (i) the same
 - (ii) much higher
 - (iii) much lesser
 - (iv) none of the above
18. A gas-filled tube has internal resistance after ionisation.
 - (i) low
 - (ii) high
 - (iii) very high
 - (iv) moderate
19. The gas-filled tubes can handle peak inverse voltage (PIV) as compared to equivalent vacuum tubes.
 - (i) more
 - (ii) less
 - (iii) the same
 - (iv) none of the above
20. A cold cathode diode is used as tube.
 - (i) a rectifier
 - (ii) a power-controlled
 - (iii) a regulating
 - (iv) an amplifier

Answers to Multiple-Choice Questions

- | | | | | |
|----------|----------|----------|-----------|-----------|
| 1. (ii) | 2. (i) | 3. (iii) | 4. (i) | 5. (iii) |
| 6. (iii) | 7. (i) | 8. (iii) | 9. (ii) | 10. (ii) |
| 11. (i) | 12. (ii) | 13. (iv) | 14. (iii) | 15. (i) |
| 16. (ii) | 17. (ii) | 18. (i) | 19. (ii) | 20. (iii) |

Chapter Review Topics

1. Explain the differences between a gas tube and equivalent vacuum tube.
2. Explain how ionisation takes place in a hot-gas diode. How does current conduction take place in such a tube ?
3. Give the schematic symbols of glow tube, hot-cathode gas diode and thyatron.
4. Explain the construction, operation and characteristics of a glow tube.
5. Discuss some applications of glow tubes.
6. What is a thyatron ? How does it differ from a vacuum triode ?
7. Write short notes on the following :
 - (i) Characteristics of hot-cathode gas diode
 - (ii) Applications of thyatrons

Discussion Questions

1. What are the advantages of gas tubes over vacuum tubes ?
2. What is the difference between the action of thyatron and vacuum triode ?
3. Why cannot thyatrons be used as rectifiers for high voltages ?
4. Can gas diodes be used as rectifiers for high voltages ?
5. What is the drawback of a gas diode compared to a thyatron ?