

14

Sinusoidal Oscillators

- 14.1 Sinusoidal Oscillator
- 14.2 Types of Sinusoidal Oscillations
- 14.3 Oscillatory Circuit
- 14.4 Undamped Oscillations from Tank Circuit
- 14.5 Positive Feedback Amplifier — Oscillator
- 14.6 Essentials of Transistor Oscillator
- 14.7 Explanation of Barkhausen Criterion
- 14.8 Different Types of Transistor Oscillators
- 14.9 Tuned Collector Oscillator
- 14.10 Colpitt's Oscillator
- 14.11 Hartley Oscillator
- 14.12 Principle of Phase Shift Oscillators
- 14.13 Phase Shift Oscillator
- 14.14 Wien Bridge Oscillator
- 14.15 Limitations of LC and RC Oscillators
- 14.16 Piezoelectric Crystals
- 14.17 Working of Quartz Crystal
- 14.18 Equivalent Circuit of Crystal
- 14.19 Frequency Response of Crystal
- 14.20 Transistor Crystal Oscillator

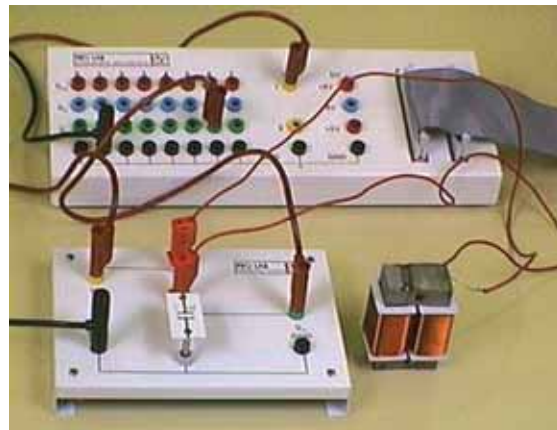

INTRODUCTION

Many electronic devices require a source of energy at a specific frequency which may range from a few Hz to several MHz. This is achieved by an electronic device called an *oscillator*. Oscillators are extensively used in electronic equipment. For example, in radio and television receivers, oscillators are used to generate high frequency wave (called *carrier wave*) in the tuning stages. Audio frequency and radio-frequency signals are required for the repair of radio, television and other electronic equipment. Oscillators are also widely used in radar, electronic computers and other electronic devices.

Oscillators can produce sinusoidal or non-sinusoidal (e.g. square wave) waves. In this chapter, we shall confine our attention to sinusoidal oscillators *i.e.* those which produce sine-wave signals.

14.1 Sinusoidal Oscillator

An electronic device that generates sinusoidal oscillations of desired frequency is known as a ***sinusoidal oscillator**.

Although we speak of an oscillator as “generating” a frequency, it should be noted that it does not create energy, but merely acts as an energy converter. It receives d.c. energy and changes it into a.c. energy of desired frequency. The frequency of oscillations depends upon the constants of the device.

It may be mentioned here that although an alternator produces sinusoidal oscillations of 50Hz, it cannot be called an oscillator. Firstly, an alternator is a mechanical device having rotating parts whereas an oscillator is a non-rotating electronic device. Secondly, an alternator converts mechanical energy into a.c. energy while an oscillator converts d.c. energy into a.c. energy. Thirdly, an alternator cannot produce high frequency oscillations whereas an oscillator can produce oscillations ranging from a few Hz to several MHz.

Advantages

Although oscillations can be produced by mechanical devices (*e.g.* alternators), but electronic oscillators have the following advantages :

- (i) An oscillator is a non-rotating device. Consequently, there is little wear and tear and hence longer life.
- (ii) Due to the absence of moving parts, the operation of an oscillator is quite silent.
- (iii) An oscillator can produce waves from small (20 Hz) to extremely high frequencies (> 100 MHz).
- (iv) The frequency of oscillations can be easily changed when desired.
- (v) It has good frequency stability *i.e.* frequency once set remains constant for a considerable period of time.
- (vi) It has very high efficiency.

14.2 Types of Sinusoidal Oscillations

Sinusoidal electrical oscillations can be of two types viz **damped oscillations** and **undamped oscillations**.

(i) Damped oscillations.

The electrical oscillations whose amplitude goes on decreasing with time are called **damped oscillations**.

Fig. 14.1 (i) shows waveform of damped electrical oscillations. Obviously, the electrical system in which these oscillations are generated has losses and some energy is lost during each oscillation.

Further, no means are provided to compensate for the losses and consequently the amplitude of the generated wave decreases gradually. It may be noted that frequency of oscillations remains unchanged since it depends upon the constants of the electrical system.

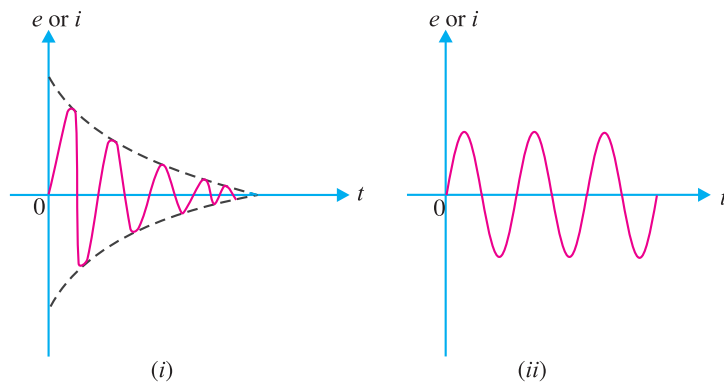

Fig. 14.1

* Note that oscillations are produced without any external signal source. The only input power to an oscillator is the d.c. power supply.

(ii) **Undamped oscillations.** The electrical oscillations whose amplitude remains constant with time are called *undamped oscillations*. Fig. 14.1 (ii) shows waveform of undamped electrical oscillations. Although the electrical system in which these oscillations are being generated has also losses, but now right amount of energy is being supplied to overcome the losses. Consequently, the amplitude of the generated wave remains constant. It should be emphasised that an oscillator is required to produce undamped electrical oscillations for utilising in various electronics equipment.

14.3 Oscillatory Circuit

A circuit which produces electrical oscillations of any desired frequency is known as an **oscillatory circuit** or **tank circuit**.

A simple oscillatory circuit consists of a capacitor (C) and inductance coil (L) in parallel as shown in Fig. 14.2. This electrical system can produce electrical oscillations of frequency determined by the values of L and C . To understand how this comes about, suppose the capacitor is charged from a d.c. source with a polarity as shown in Fig. 14.2 (i).

(i) In the position shown in Fig. 14.2 (i), the upper plate of capacitor has deficit of electrons and the lower plate has excess of electrons. Therefore, there is a voltage across the capacitor and the capacitor has electrostatic energy.

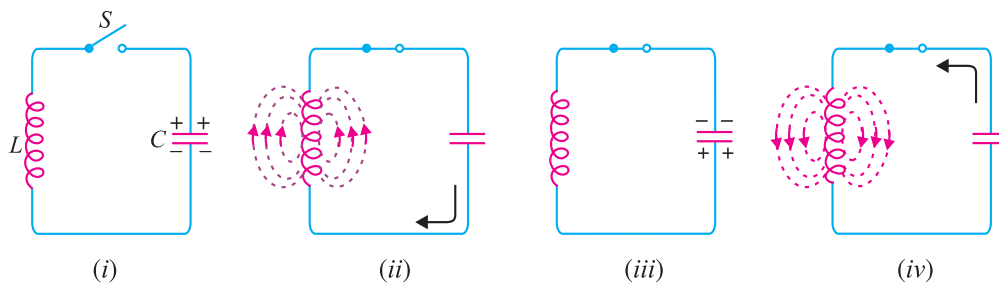

Fig. 14.2

(ii) When switch S is closed as shown in Fig. 14.2 (ii), the capacitor will discharge through inductance and the electron flow will be in the direction indicated by the arrow. This current flow sets up magnetic field around the coil. Due to the inductive effect, the current builds up slowly towards a maximum value. The circuit current will be maximum when the capacitor is fully discharged. At this instant, electrostatic energy is zero but because electron motion is greatest (*i.e.* maximum current), the magnetic field energy around the coil is maximum. This is shown in Fig. 14.2 (ii). Obviously, the electrostatic energy across the capacitor is completely converted into magnetic field energy around the coil.

(iii) Once the capacitor is discharged, the magnetic field will begin to collapse and produce a counter e.m.f. According to Lenz's law, the counter e.m.f. will keep the current flowing in the same direction. The result is that the capacitor is now charged with opposite polarity, making upper plate of capacitor negative and lower plate positive as shown in Fig. 14.2 (iii).

(iv) After the collapsing field has recharged the capacitor, the capacitor now begins to discharge; current now flowing in the opposite direction. Fig. 14.2 (iv) shows capacitor fully discharged and maximum current flowing.

The sequence of charge and discharge results in alternating motion of electrons or an oscillating current. The energy is alternately stored in the electric field of the capacitor (C) and the magnetic field of the inductance coil (L). This interchange of energy between L and C is repeated over and again resulting in the production of oscillations.

Waveform. If there were no losses in the tank circuit to consume the energy, the interchange of energy between L and C would continue indefinitely. In a practical tank circuit, there are resistive and radiation losses in the coil and dielectric losses in the capacitor. During each cycle, a small part of the originally imparted energy is used up to overcome these losses. The result is that the amplitude of oscillating current decreases gradually and eventually it becomes zero when all the energy is consumed as losses. Therefore, the tank circuit by itself will produce *damped oscillations* as shown in Fig. 14.3.

Frequency of oscillations. The frequency of oscillations in the tank circuit is determined by the constants of the circuit viz L and C . The actual frequency of oscillations is the resonant frequency (or natural frequency) of the tank circuit given by :

$$f_r = \frac{1}{2\pi\sqrt{LC}}$$

It is clear that frequency of oscillations in the tank circuit is inversely proportional to L and C . This can be easily explained. If a large value of capacitor is used, it will take longer for the capacitor to charge fully and also longer to discharge. This will lengthen the period of oscillations in the tank circuit, or equivalently lower its frequency. With a large value of inductance, the opposition to change in current flow is greater and hence the time required to complete each cycle will be longer. Therefore, the greater the value of inductance, the longer is the period or the lower is the frequency of oscillations in the tank circuit.

14.4. Undamped Oscillations from Tank Circuit

As discussed before, a tank circuit produces damped oscillations. However, in practice, we need continuous undamped oscillations for the successful operation of electronics equipment. In order to make the oscillations in the tank circuit undamped, it is necessary to supply correct amount of energy to the tank circuit at the proper time intervals to meet the losses. Thus referring back to Fig. 14.2, any energy which would be applied to the circuit must have a polarity conforming to the existing polarity at the instant of application of energy. If the applied energy is of opposite polarity, it would oppose the energy in the tank circuit, causing stoppage of oscillations. Therefore, in order to make the oscillations in the tank circuit undamped, the following conditions must be fulfilled :

- (i) The amount of energy supplied should be such so as to meet the losses in the tank circuit and the a.c. energy removed from the circuit by the load. For instance, if losses in LC circuit amount to 5 mW and a.c. output being taken is 100 mW, then power of 105 mW should be continuously supplied to the circuit.
- (ii) The applied energy should have the same frequency as that of the oscillations in the tank circuit.
- (iii) The applied energy should be in phase with the oscillations set up in the tank circuit *i.e.* it should aid the tank circuit oscillations.

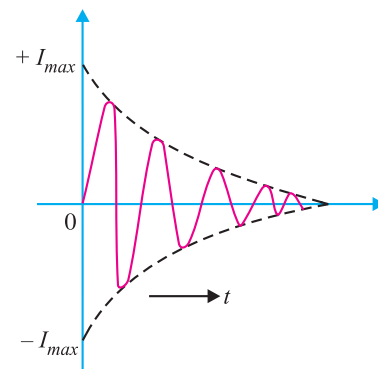

Fig. 14.3

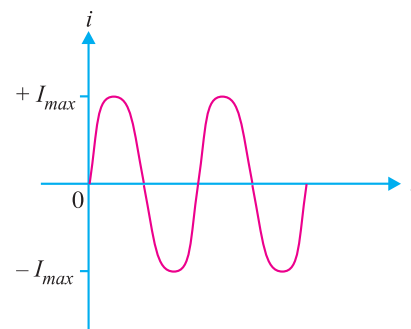

Fig. 14.4

If these conditions are fulfilled, the circuit will produce continuous undamped output as shown in Fig. 14.4.

14.5. Positive Feedback Amplifier — Oscillator

A transistor amplifier with *proper* positive feedback can act as an oscillator *i.e.*, it can generate oscillations without any external signal source. Fig. 14.5 shows a transistor amplifier with positive

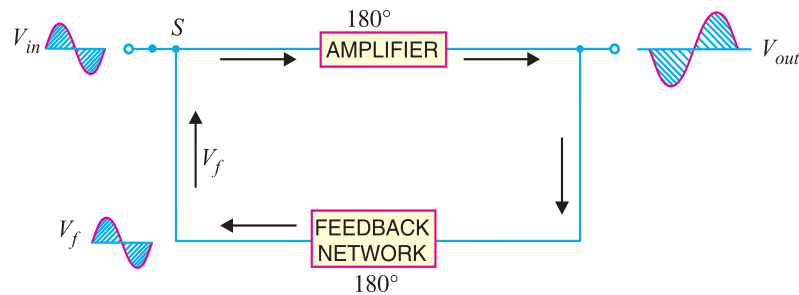

Fig. 14.5

feedback. Remember that a positive feedback amplifier is one that produces a feedback voltage (V_f) that *is in phase* with the original input signal. As you can see, this condition is met in the circuit shown in Fig. 14.5. A phase shift of 180° is produced by the amplifier and a further phase shift of 180° is introduced by feedback network. Consequently, the signal is shifted by 360° and fed to the input *i.e.*, feedback voltage is in phase with the input signal.

(i) We note that the circuit shown in Fig. 14.5 is producing oscillations in the output. However, this circuit has an input signal. This is inconsistent with our definition of an oscillator *i.e.*, an oscillator is a circuit that produces oscillations without any external signal source.



Positive Feedback Amplifier

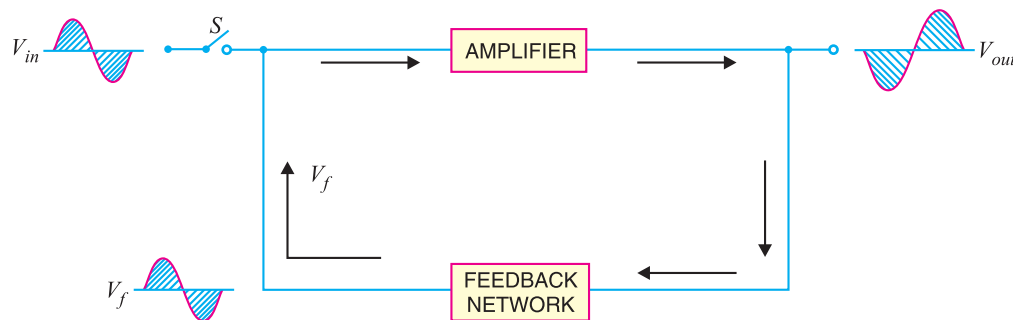

Fig. 14.6

(ii) When we open the switch S of Fig. 14.5, we get the circuit shown in Fig. 14.6. This means the input signal (V_{in}) is removed. However, V_f (which is in phase with the original signal) is still applied to the input signal. The amplifier will respond to this signal in the same way that it did to V_{in} *i.e.*, V_f will be amplified and sent to the output. The feedback network sends a portion of the output back to the input. Therefore, the amplifier receives another input cycle and another output cycle is produced. This process will continue so long as the amplifier is turned on. Therefore, the amplifier will produce

sinusoidal output with no external signal source. The following points may be noted carefully :

- (a) A transistor amplifier with proper *positive* feedback will work as an oscillator.
- (b) The circuit needs only a quick trigger signal to start the oscillations. Once the oscillations have started, no external signal source is needed.
- (c) In order to get continuous undamped output from the circuit, the following condition must be met :

$$m_v A_v = 1$$

where A_v = voltage gain of amplifier without feedback

m_v = feedback fraction

This relation is called *Barkhausen criterion*. This condition will be explained in the Art. 14.7.

14.6 Essentials of Transistor Oscillator

Fig. 14.7 shows the block diagram of an oscillator. Its essential components are :

(i) **Tank circuit.** It consists of inductance coil (L) connected in parallel with capacitor (C). The frequency of oscillations in the circuit depends upon the values of inductance of the coil and capacitance of the capacitor.

(ii) **Transistor amplifier.** The transistor amplifier receives d.c. power from the battery and changes it into a.c. power for supplying to the tank circuit. The oscillations occurring in the tank circuit are applied to the input of the transistor amplifier. Because of the amplifying properties of the transistor, we get increased output of these oscillations.

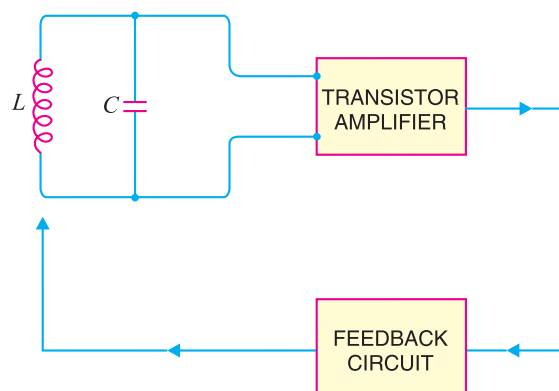

Fig. 14.7

This amplified output of oscillations is due to the d.c. power supplied by the battery. The output of the transistor can be supplied to the tank circuit to meet the losses.

(iii) **Feedback circuit.** The feedback circuit supplies a part of collector energy to the tank circuit in correct phase to aid the oscillations *i.e.* it provides positive feedback.

14.7 Explanation of Barkhausen Criterion

Barkhausen criterion is that in order to produce continuous undamped oscillations at the output of an amplifier, the positive feedback should be such that :

$$m_v A_v = 1$$

Once this condition is set in the positive feedback amplifier, continuous undamped oscillations can be obtained at the output immediately after connecting the necessary power supplies.

370 ■ Principles of Electronics

(i) **Mathematical explanation.** The voltage gain of a positive feedback amplifier is given by;

$$A_{vf} = \frac{A_v}{1 - m_v A_v}$$

If $m_v A_v = 1$, then $A_{vf} \rightarrow \infty$.

We know that we cannot achieve infinite gain in an amplifier. So what does this result infer in physical terms? It means that a vanishing small input voltage would give rise to finite (*i.e.*, a definite amount of) output voltage even when the input signal is zero. Thus once the circuit receives the input trigger, it would become an oscillator, generating oscillations with no external signal source.

(ii) **Graphical Explanation.** Let us discuss the condition $m_v A_v = 1$ graphically. Suppose the voltage gain of the amplifier without positive feedback is 100. In order to produce continuous

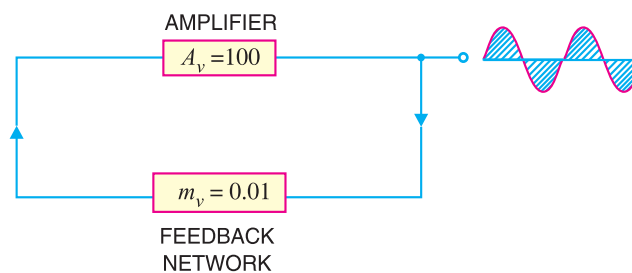

Fig. 14.8

undamped oscillations, $m_v A_v = 1$ or $m_v \times 100 = 1$ or $m_v = 0.01$. This is illustrated in Fig. 14.8. Since the condition $m_v A_v = 1$ is met in the circuit shown in Fig. 14.8, it will produce sustained oscillations.

Suppose the initial triggering voltage is 0.1V peak. Starting with this value, circuit ($A_v = 100$; $m_v = 0.01$) will progress as follows.

Cycle	V_{in}	V_{out}	V_f
1.	0.1Vpk	10Vpk	0.1Vpk
2.	0.1Vpk	10Vpk	0.1Vpk

The same thing will repeat for 3rd, 4th cycles and so on. Note that during each cycle, $V_f = 0.1Vpk$ and $V_{out} = 10Vpk$. Clearly, the oscillator is producing continuous undamped oscillations.

Note. The relation $m_v A_v = 1$ holds good for true ideal circuits. However, practical circuits need an $m_v A_v$ product that is slightly greater than 1. This is to compensate for power loss (*e.g.*, in resistors) in the circuit.

14.8 Different Types of Transistor Oscillators

A transistor can work as an oscillator to produce continuous undamped oscillations of any desired frequency if tank and feedback circuits are properly connected to it. All oscillators under different names have similar function *i.e.*, they produce continuous undamped output. However, the major difference between these oscillators lies in the method by which energy is supplied to the tank circuit to meet the losses. The following are the transistor oscillators commonly used at various places in electronic circuits :

- (i) Tuned collector oscillator
- (ii) Colpitt's oscillator
- (iii) Hartley oscillator
- (iv) Phase shift oscillator
- (v) Wien Bridge oscillator
- (vi) Crystal oscillator

14.9 Tuned Collector Oscillator

Fig.14.9 shows the circuit of tuned collector oscillator. It contains tuned circuit L_1 - C_1 in the collector and hence the name. The frequency of oscillations depends upon the values of L_1 and C_1 and is given by :

$$f = \frac{1}{2\pi\sqrt{L_1 C_1}} \quad \dots(i)$$

The feedback coil L_2 in the base circuit is magnetically coupled to the tank circuit coil L_1 . In practice, L_1 and L_2 form the primary and secondary of the transformer respectively. The biasing is provided by potential divider arrangement. The capacitor C connected in the base circuit provides low reactance path to the oscillations.

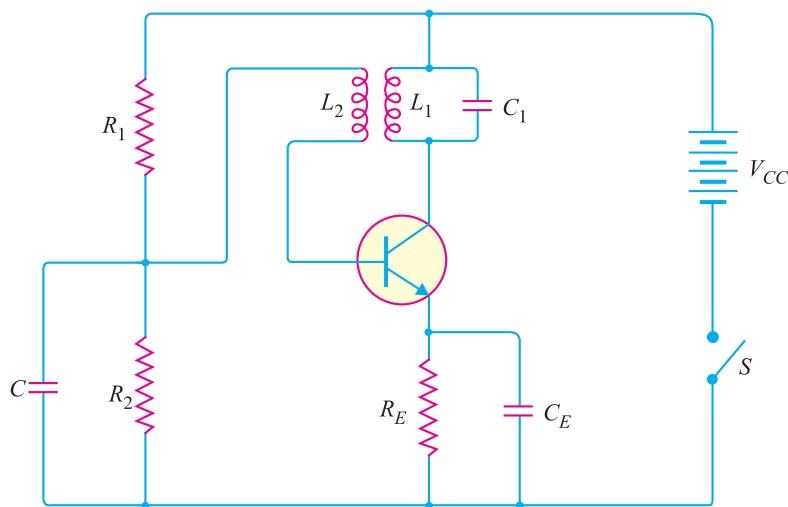

Fig. 14.9

Circuit operation. When switch S is closed, collector current starts increasing and charges the capacitor C_1 . When this capacitor is fully charged, it discharges through coil L_1 , setting up oscillations of frequency determined by exp. (i). These oscillations induce some voltage in coil L_2 by mutual induction. The frequency of voltage in coil L_2 is the same as that of tank circuit but its magnitude depends upon the number of turns of L_2 and coupling between L_1 and L_2 . The voltage across L_2 is applied between base and emitter and appears in the amplified form in the collector circuit, thus overcoming the losses occurring in the tank circuit. The number of turns of L_2 and coupling between L_1 and L_2 are so adjusted that oscillations across L_2 are amplified to a level just sufficient to supply losses to the tank circuit.

It may be noted that the phase of feedback is correct *i.e.* energy supplied to the tank circuit is in phase with the generated oscillations. A phase shift of 180° is created between the voltages of L_1 and L_2 due to transformer *action. A further phase shift of 180° takes place between base-emitter and collector circuit due to transistor properties. As a result, the energy feedback to the tank circuit is in phase with the generated oscillations.

Example 14.1. The tuned collector oscillator circuit used in the local oscillator of a radio

* All transformers introduce a phase shift of 180° between primary and secondary.

372 ■ Principles of Electronics

receiver makes use of an LC tuned circuit with $L_1 = 58.6 \mu\text{H}$ and $C_1 = 300 \text{ pF}$. Calculate the frequency of oscillations.

Solution.

$$L_1 = 58.6 \mu\text{H} = 58.6 \times 10^{-6} \text{ H}$$

$$C_1 = 300 \text{ pF} = 300 \times 10^{-12} \text{ F}$$

$$\begin{aligned} \text{Frequency of oscillations, } f &= \frac{1}{2\pi \sqrt{L_1 C_1}} \\ &= \frac{1}{2\pi \sqrt{58.6 \times 10^{-6} \times 300 \times 10^{-12}}} \text{ Hz} \\ &= 1199 \times 10^3 \text{ Hz} = \mathbf{1199 \text{ kHz}} \end{aligned}$$

Example 14.2. Find the capacitance of the capacitor required to build an LC oscillator that uses an inductance of $L_1 = 1 \text{ mH}$ to produce a sine wave of frequency 1 GHz ($1 \text{ GHz} = 1 \times 10^{12} \text{ Hz}$).

Solution.

Frequency of oscillations is given by ;

$$f = \frac{1}{2\pi \sqrt{L_1 C_1}}$$

or

$$\begin{aligned} C_1 &= \frac{1}{L_1 (2\pi f)^2} = \frac{1}{(1 \times 10^{-3}) (2\pi \times 1 \times 10^{12})^2} \\ &= 2.53 \times 10^{-23} \text{ F} = \mathbf{2.53 \times 10^{-11} \text{ pF}} \end{aligned}$$

The LC circuit is often called *tuned circuit* or *tank circuit*.

14.10 Colpitt's Oscillator

Fig. 14.10 shows a Colpitt's oscillator. It uses two capacitors and placed across a common inductor L and the centre of the two capacitors is tapped. The tank circuit is made up of C_1 , C_2 and L . The frequency of oscillations is determined by the values of C_1 , C_2 and L and is given by ;

$$f = \frac{1}{2\pi \sqrt{LC_T}} \quad \dots(i)$$

where

$$C_T = \frac{C_1 C_2}{C_1 + C_2}$$

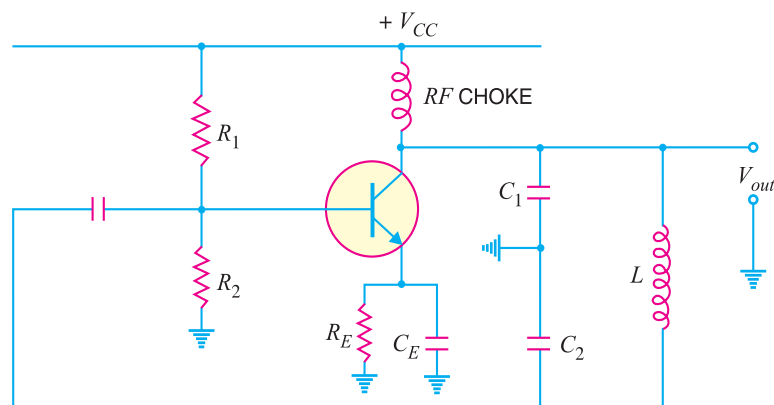

Fig. 14.10

*Note that $C_1 - C_2 - L$ is also the feedback circuit that produces a phase shift of 180° .

Circuit operation. When the circuit is turned on, the capacitors C_1 and C_2 are charged. The capacitors discharge through L , setting up oscillations of frequency determined by exp.** (i). The output voltage of the amplifier appears across C_1 and feedback voltage is developed across C_2 . The voltage across it is 180° out of phase with the voltage developed across C_1 (V_{out}) as shown in Fig. 14.11. It is easy to see that voltage feedback (voltage across C_2) to the transistor provides positive feedback. A phase shift of 180° is produced by the transistor and a further phase shift of 180° is produced by $C_1 - C_2$ voltage divider. In this way, feedback is properly phased to produce continuous undamped oscillation.

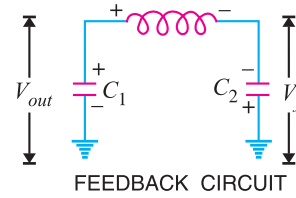

Fig. 14.11

Feedback fraction m_v . The amount of feedback voltage in Colpitt's oscillator depends upon feedback fraction m_v of the circuit. For this circuit,

$$\text{Feedback fraction, } m_v = \frac{V_f}{V_{out}} = \frac{X_{c2}}{X_{c1}} = \frac{C_1^{***}}{C_2}$$

or
$$m_v = \frac{C_1}{C_2}$$

Example 14.3. Determine the (i) operating frequency and (ii) feedback fraction for Colpitt's oscillator shown in Fig. 14.12.

Solution.

(i) **Operating Frequency.** The operating frequency of the circuit is always equal to the resonant frequency of the feedback network. As noted previously, the capacitors C_1 and C_2 are in series.

$$\begin{aligned} \therefore C_T &= \frac{C_1 C_2}{C_1 + C_2} = \frac{0.001 \times 0.01}{0.001 + 0.01} = 9.09 \times 10^{-4} \mu\text{F} \\ &= 909 \times 10^{-12} \text{ F} \\ L &= 15 \mu\text{H} = 15 \times 10^{-6} \text{ H} \end{aligned}$$

$$\begin{aligned} \therefore \text{Operating frequency, } f &= \frac{1}{2\pi \sqrt{LC_T}} \\ &= \frac{1}{2\pi \sqrt{15 \times 10^{-6} \times 909 \times 10^{-12}}} \text{ Hz} \\ &= 1361 \times 10^3 \text{ Hz} = \mathbf{1361 \text{ kHz}} \end{aligned}$$

(ii) **Feedback fraction**

$$m_v = \frac{C_1}{C_2} = \frac{0.001}{0.01} = \mathbf{0.1}$$

* The RF choke decouples any ac signal on the power lines from affecting the output signal.

** Referring to Fig. 14.11, it is clear that C_1 and C_2 are in series. Therefore, total capacitance C_T is given by;

$$C_T = \frac{C_1 C_2}{C_1 + C_2}$$

*** Referring to Fig. 14.11, the circulating current for the two capacitors is the same. Further, capacitive reactance is inversely proportional to capacitance.

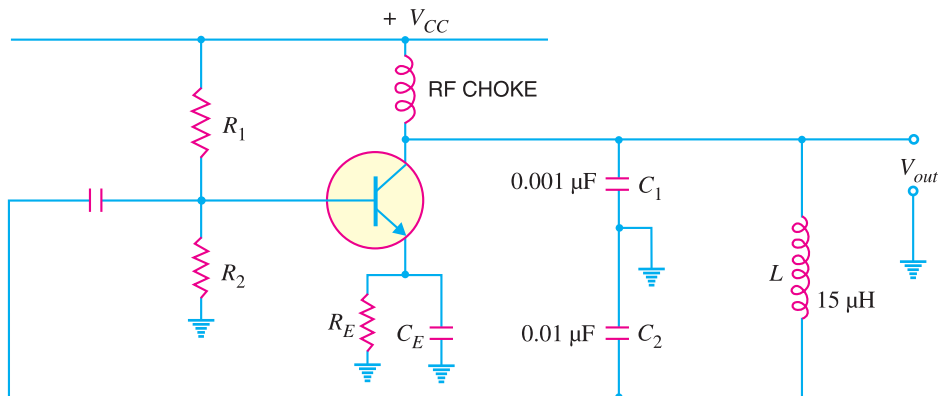

Fig. 14.12

Example 14.4. A 1 mH inductor is available. Choose the capacitor values in a Colpitts oscillator so that $f = 1$ MHz and $m_v = 0.25$.

Solution.

Feedback fraction, $m_v = \frac{C_1}{C_2}$

or $0.25 = \frac{C_1}{C_2} \quad \therefore C_2 = 4C_1$

Now $f = \frac{1}{2\pi \sqrt{LC_T}}$

or $C_T = \frac{1}{L(2\pi f)^2} = \frac{1}{(1 \times 10^{-3})(2\pi \times 1 \times 10^6)^2} = 25.3 \times 10^{-12} \text{ F}$
 $= 25.3 \text{ pF}$

or $\frac{C_1 C_2}{C_1 + C_2} = 25.3 \text{ pF} \quad \left[\because C_T = \frac{C_1 C_2}{C_1 + C_2} \right]$

or $1 + \frac{C_2}{C_1} = 25.3$

or $\frac{C_2}{1 + 4} = 25.3 \quad \therefore C_2 = 25.3 \times 5 = \mathbf{126.5 \text{ pF}}$

and $C_1 = C_2/4 = 126.5/4 = \mathbf{31.6 \text{ pF}}$

14.11 Hartley Oscillator

The Hartley oscillator is similar to Colpitt's oscillator with minor modifications. Instead of using tapped capacitors, two inductors L_1 and L_2 are placed across a common capacitor C and the centre of the inductors is tapped as shown in Fig. 14.13. The tank circuit is made up of L_1 , L_2 and C . The frequency of oscillations is determined by the values of L_1 , L_2 and C and is given by :

$$f = \frac{1}{2\pi \sqrt{CL_T}} \quad \dots(i)$$

where $L_T = L_1 + L_2 + 2M$

Here $M =$ mutual inductance between L_1 and L_2

Note that $L_1 - L_2 - C$ is also the feedback network that produces a phase shift of 180° .

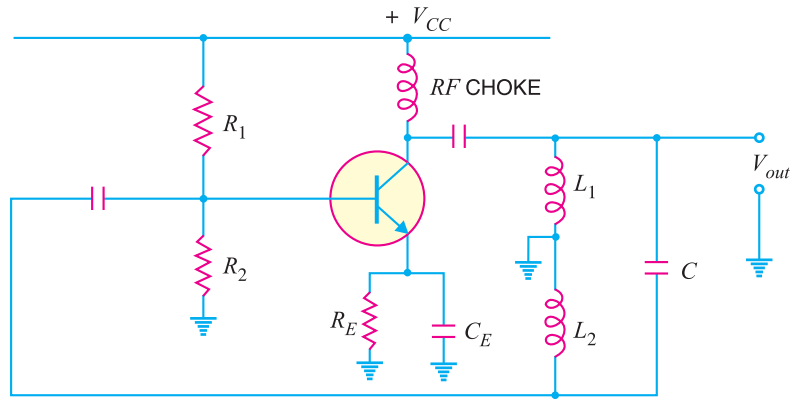

Fig. 14.13

Circuit operation. When the circuit is turned on, the capacitor is charged. When this capacitor is fully charged, it discharges through coils L_1 and L_2 setting up oscillations of frequency determined by *exp. (i). The output voltage of the amplifier appears across L_1 and feedback voltage across L_2 . The voltage across L_2 is 180° out of phase with the voltage developed across L_1 (V_{out}) as shown in Fig. 14.14. It is easy to see that voltage feedback (i.e., voltage across L_2) to the transistor provides positive feedback. A phase shift of 180° is produced by the transistor and a further phase shift of 180° is produced by $L_1 - L_2$ voltage divider. In this way, feedback is properly phased to produce continuous undamped oscillations.

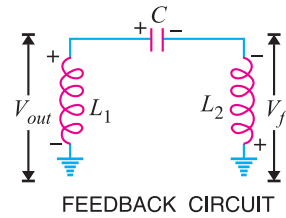

Fig. 14.14

Feedback fraction m_v . In Hartley oscillator, the feedback voltage is across L_2 and output voltage is across L_1 .

$$\therefore \text{Feedback fraction, } m_v = \frac{V_f}{V_{out}} = \frac{X_{L_2}}{X_{L_1}} = \frac{L_2}{L_1}$$

or

$$m_v = \frac{L_2}{L_1}$$

Example 14.5. Calculate the (i) operating frequency and (ii) feedback fraction for Hartley oscillator shown in Fig. 14.15. The mutual inductance between the coils, $M = 20 \mu\text{H}$.

Solution.

(i)

$$L_1 = 1000 \mu\text{H}; \quad L_2 = 100 \mu\text{H}; \quad M = 20 \mu\text{H}$$

$$\therefore \text{Total inductance, } L_T = L_1 + L_2 + 2M$$

$$= 1000 + 100 + 2 \times 20 = 1140 \mu\text{H} = 1140 \times 10^{-6} \text{H}$$

$$\text{Capacitance, } C = 20 \text{ pF} = 20 \times 10^{-12} \text{F}$$

* Referring to Fig. 14.14, it is clear that L_1 and L_2 are in series. Therefore, total inductance L_T is given by : $L_T = L_1 + L_2 + 2M$
 ** Referring to Fig. 14.14, the circulating current for the two inductors is the same. Further, inductive reactance is directly proportional to inductance.

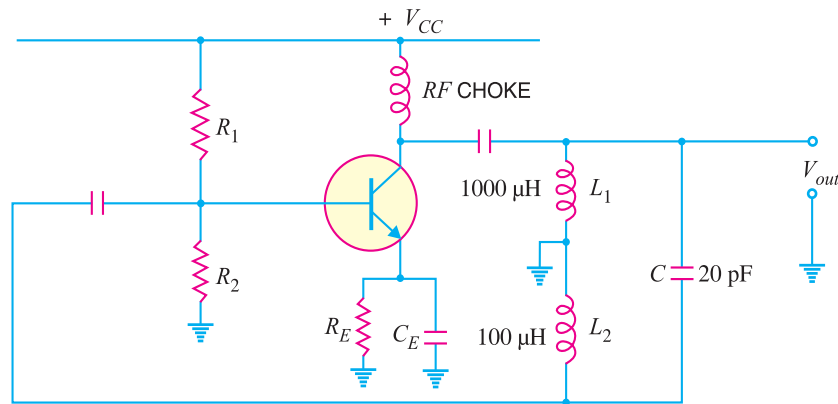

Fig. 14.15

$$\begin{aligned} \therefore \text{Operating frequency, } f &= \frac{1}{2\pi \sqrt{L_T C}} = \frac{1}{2\pi \sqrt{1140 \times 10^{-6} \times 20 \times 10^{-12}}} \text{ Hz} \\ &= 1052 \times 10^3 \text{ Hz} = \mathbf{1052 \text{ kHz}} \\ \text{(ii) Feedback fraction, } m_v &= \frac{L_2}{L_1} = \frac{100 \mu\text{H}}{1000 \mu\text{H}} = \mathbf{0.1} \end{aligned}$$

Example 14.6. A 1 pF capacitor is available. Choose the inductor values in a Hartley oscillator so that $f = 1 \text{ MHz}$ and $m_v = 0.2$.

Solution.

$$\begin{aligned} \text{Feedback fraction, } m_v &= \frac{L_2}{L_1} \\ \text{or } 0.2 &= \frac{L_2}{L_1} \quad \therefore L_1 = 5L_2 \\ \text{Now } f &= \frac{1}{2\pi \sqrt{L_T C}} \\ \text{or } L_T &= \frac{1}{C(2\pi f)^2} = \frac{1}{(1 \times 10^{-12})(2\pi \times 1 \times 10^6)^2} \\ &= 25.3 \times 10^{-3} \text{ H} = 25.3 \text{ mH} \\ \text{or } L_1 + L_2 &= 25.3 \text{ mH} \quad (\because L_T = L_1 + L_2) \\ \text{or } 5L_2 + L_2 &= 25.3 \quad \therefore L_2 = 25.3/6 = \mathbf{4.22 \text{ mH}} \\ \text{and } L_1 &= 5L_2 = 5 \times 4.22 = \mathbf{21.1 \text{ mH}} \end{aligned}$$

14.12 Principle of Phase Shift Oscillators

One desirable feature of an oscillator is that it should feed back energy of correct phase to the tank circuit to overcome the losses occurring in it. In the oscillator circuits discussed so far, the tank circuit employed inductive (L) and capacitive (C) elements. In such circuits, a phase shift of 180° was obtained due to inductive or capacitive coupling and a further phase shift of 180° was obtained due to transistor properties. In this way, energy supplied to the tank circuit was in phase with the generated oscillations. The oscillator circuits employing L - C elements have two general drawbacks. Firstly, they suffer from frequency instability and poor waveform. Secondly, they cannot be used for very low frequencies because they become too much bulky and expensive.

Good frequency stability and waveform can be obtained from oscillators employing resistive and capacitive elements. Such amplifiers are called *R-C* or *phase shift oscillators* and have the additional advantage that they can be used for very low frequencies. In a phase shift oscillator, a phase shift of 180° is obtained with a phase shift circuit instead of inductive or capacitive coupling. A further phase shift of 180° is introduced due to the transistor properties. Thus, energy supplied back to the tank circuit is assured of correct phase.

Phase shift circuit. A phase-shift circuit essentially consists of an *R-C* network. Fig. 14.16 (i) shows a single section of *RC* network. From the elementary theory of electrical engineering, it can be shown that alternating voltage V'_1 across *R* leads the applied voltage V_1 by ϕ° . The value of ϕ depends upon the values of *R* and *C*. If resistance *R* is varied, the value of ϕ also changes. If *R* were reduced to zero, V'_1 will lead V_1 by 90° i.e. $\phi = 90^\circ$. However, adjusting *R* to zero would be impracticable because it would lead to no voltage across *R*. Therefore, in practice, *R* is varied to such a value that makes V'_1 to lead V_1 by 60° .

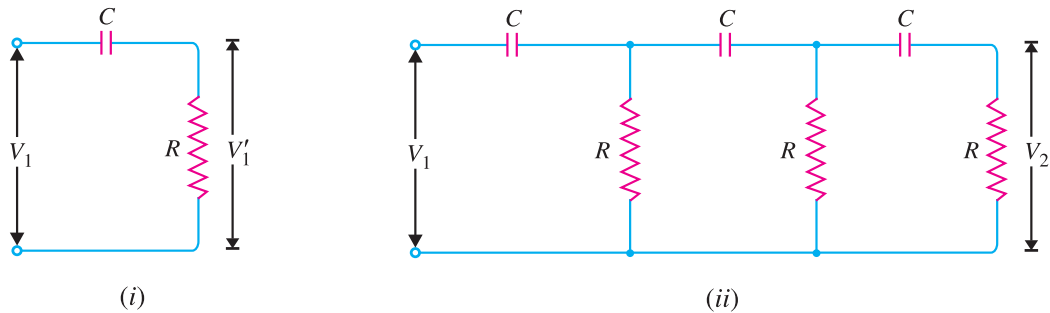

Fig. 14.16

Fig. 14.16 (ii) shows the three sections of *RC* network. Each section produces a phase shift of 60° . Consequently, a total phase shift of 180° is produced i.e. voltage V_2 leads the voltage V_1 by 180° .

14.13 Phase Shift Oscillator

Fig.14.17 shows the circuit of a phase shift oscillator. It consists of a conventional single transistor amplifier and a *RC* phase shift network. The phase shift network consists of three sections R_1C_1 , R_2C_2 and R_3C_3 . At some particular frequency f_0 , the phase shift in each *RC* section is 60° so that the total phase-shift produced by the *RC* network is 180° . The frequency of oscillations is given by :

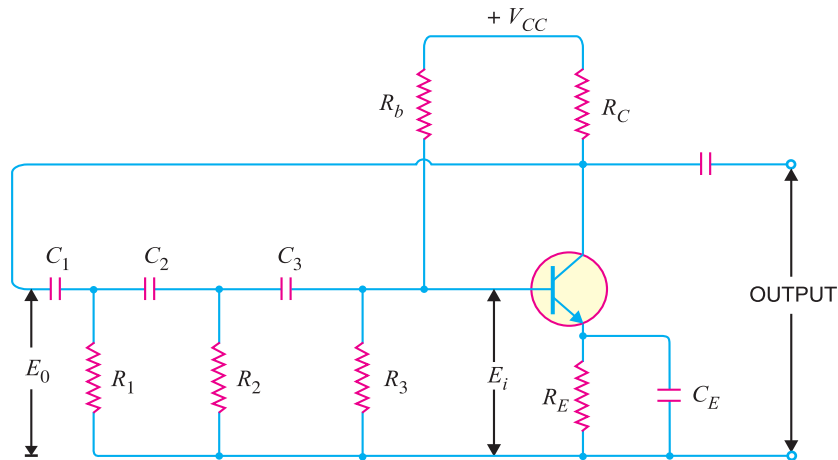

Fig. 14.17

378 ■ Principles of Electronics

$$f_0 = \frac{1}{2\pi RC\sqrt{6}} \quad \dots(i)$$

where

$$\begin{aligned} R_1 &= R_2 = R_3 = R \\ C_1 &= C_2 = C_3 = C \end{aligned}$$

Circuit operation. When the circuit is switched on, it produces oscillations of frequency determined by exp. (i). The output E_0 of the amplifier is fed back to RC feedback network. This network produces a phase shift of 180° and a voltage E_i appears at its output which is applied to the transistor amplifier.

Obviously, the feedback fraction $m = E_i/E_0$. The feedback phase is correct. A phase shift of 180° is produced by the transistor amplifier. A further phase shift of 180° is produced by the RC network. As a result, the phase shift around the entire loop is 360° .

Advantages

- (i) It does not require transformers or inductors.
- (ii) It can be used to produce very low frequencies.
- (iii) The circuit provides good frequency stability.

Disadvantages

- (i) It is difficult for the circuit to start oscillations as the feedback is generally small.
- (ii) The circuit gives small output.

Example 14.7. In the phase shift oscillator shown in Fig. 14.17, $R_1 = R_2 = R_3 = 1M\Omega$ and $C_1 = C_2 = C_3 = 68 pF$. At what frequency does the circuit oscillate ?

Solution.

$$\begin{aligned} R_1 &= R_2 = R_3 = R = 1 M\Omega = 10^6 \Omega \\ C_1 &= C_2 = C_3 = C = 68 pF = 68 \times 10^{-12} F \end{aligned}$$

Frequency of oscillations is

$$\begin{aligned} f_o &= \frac{1}{2\pi RC\sqrt{6}} \\ &= \frac{1}{2\pi \times 10^6 \times 68 \times 10^{-12} \sqrt{6}} \text{ Hz} \\ &= \mathbf{954 \text{ Hz}} \end{aligned}$$

Example 14.8. A phase shift oscillator uses 5 pF capacitors. Find the value of R to produce a frequency of 800 kHz.

Solution.

$$\begin{aligned} f_o &= \frac{1}{2\pi RC\sqrt{6}} \\ \text{or} \quad R &= \frac{1}{2\pi f_o C \sqrt{6}} = \frac{1}{2\pi \times 800 \times 10^3 \times 5 \times 10^{-12} \times \sqrt{6}} \\ &= 16.2 \times 10^3 \Omega = \mathbf{16.2 \text{ k}\Omega} \end{aligned}$$

14.14 Wien Bridge Oscillator

The Wien-bridge oscillator is the standard oscillator circuit for all frequencies in the range of 10 Hz to about 1 MHz. It is the most frequently used type of audio oscillator as the output is free from circuit fluctuations and ambient temperature. Fig. 14.18 shows the circuit of Wien bridge oscillator. It is essentially a two-stage amplifier with R - C bridge circuit. The bridge circuit has the arms $R_1 C_1$,

R_3 , R_2C_2 and tungsten lamp L_p . Resistances R_3 and L_p are used to stabilise the amplitude of the output. The transistor T_1 serves as an oscillator and amplifier while the other transistor T_2 serves as an inverter (*i.e.* to produce a phase shift of 180°). The circuit uses positive and negative feedbacks. The positive feedback is through R_1C_1 , C_2R_2 to the transistor T_1 . The negative feedback is through the voltage divider to the input of transistor T_2 . The frequency of oscillations is determined by the series element R_1C_1 and parallel element R_2C_2 of the bridge.

$$f = \frac{1}{2\pi \sqrt{R_1 C_1 R_2 C_2}}$$

If $R_1 = R_2 = R$
and $C_1 = C_2 = C$, then,

$$f = \frac{1}{2\pi RC} \quad \dots(i)$$

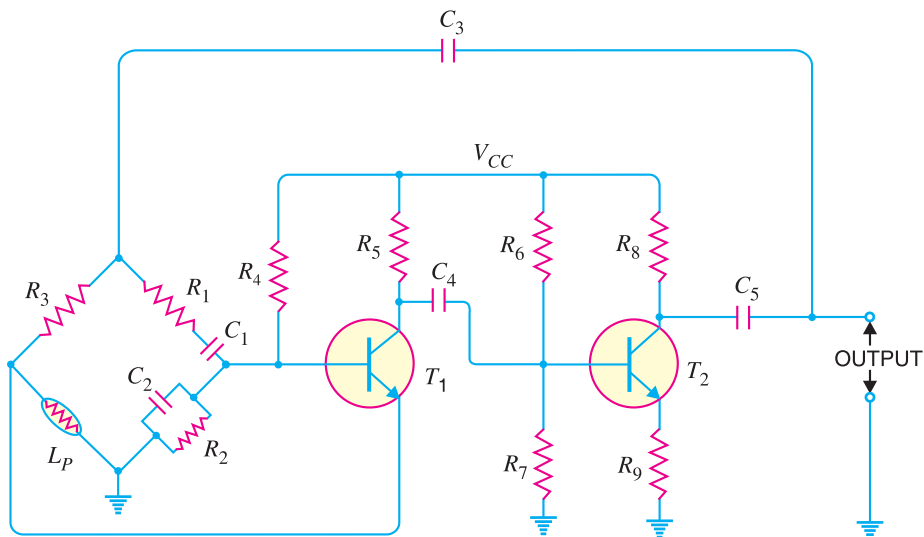

Fig. 14.18

When the circuit is started, bridge circuit produces oscillations of frequency determined by exp. (i). The two transistors produce a total phase shift of 360° so that proper positive feedback is ensured. The negative feedback in the circuit ensures constant output. This is achieved by the temperature sensitive tungsten lamp L_p . Its resistance increases with current. Should the amplitude of output tend to increase, more current would provide more negative feedback. The result is that the output would return to original value. A reverse action would take place if the output tends to decrease.

Advantages

- (i) It gives constant output.
- (ii) The circuit works quite easily.
- (iii) The overall gain is high because of two transistors.
- (iv) The frequency of oscillations can be easily changed by using a potentiometer.

Disadvantages

- (i) The circuit requires two transistors and a large number of components.
- (ii) It cannot generate very high frequencies.

Example 14.9. In the Wien bridge oscillator shown in Fig. 14.18, $R_1 = R_2 = 220 \text{ k}\Omega$ and $C_1 = C_2 = 250 \text{ pF}$. Determine the frequency of oscillations.

Solution.

$$R_1 = R_2 = R = 220 \text{ k}\Omega = 220 \times 10^3 \Omega$$

$$C_1 = C_2 = C = 250 \text{ pF} = 250 \times 10^{-12} \text{ F}$$

$$\begin{aligned} \text{Frequency of oscillations, } f &= \frac{1}{2\pi RC} \\ &= \frac{1}{2\pi \times 220 \times 10^3 \times 250 \times 10^{-12}} \text{ Hz} \\ &= \mathbf{2892 \text{ Hz}} \end{aligned}$$

14.15 Limitations of LC and RC Oscillators

The LC and RC oscillators discussed so far have their own limitations. The major problem in such circuits is that their operating frequency does not remain strictly constant. There are two principal reasons for it viz.,

- (i) As the circuit operates, it will warm up. Consequently, the values of resistors and inductors, which are the frequency determining factors in these circuits, will change with temperature. This causes the change in frequency of the oscillator.
- (ii) If any component in the feedback network is changed, it will shift the operating frequency of the oscillator.

However, in many applications, it is desirable and necessary to maintain the frequency constant with extreme low tolerances. For example, the frequency tolerance for a broadcasting station should not exceed 0.002% i.e. change in frequency due to any reason should not be more than 0.002% of the specified frequency. The broadcasting stations have frequencies which are quite close to each other. In fact, the frequency difference between two broadcasting stations is less than 1%. It is apparent that if we employ LC or RC circuits, a change of temperature may cause the frequencies of adjacent broadcasting stations to overlap.

In order to maintain constant frequency, *piezoelectric crystals* are used in place of LC or RC circuits. Oscillators of this type are called *crystal oscillators*. The frequency of a crystal oscillator changes by less than 0.1% due to temperature and other changes. Therefore, such oscillators offer the most satisfactory method of stabilising the frequency and are used in great majority of electronic applications.

14.16 Piezoelectric Crystals

Certain crystalline materials, namely, Rochelle salt, quartz and tourmaline exhibit the *piezoelectric effect* i.e., when we apply an a.c. voltage across them, they vibrate at the frequency of the applied voltage. Conversely, when they are compressed or placed under mechanical strain to vibrate, they produce an a.c. voltage. Such crystals which exhibit piezoelectric effect are called *piezoelectric crystals*. Of the various piezoelectric crystals, quartz is most commonly used because it is inexpensive and readily available in nature.

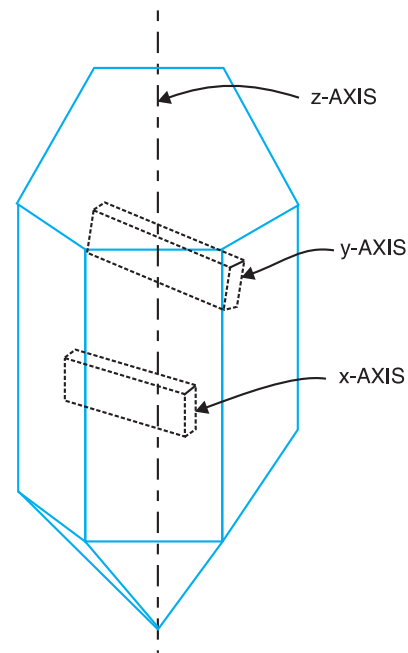

Fig. 14.19

Quartz crystal. Quartz crystals are generally used in crystal oscillators because of their great mechanical strength and simplicity of manufacture. The natural shape of quartz crystal is hexagonal as shown in Fig. 14.19. The three axes are shown : the *z-axis* is called the *optical axis*, the *x-axis* is called the *electrical axis* and *y-axis* is called the *mechanical axis*. Quartz crystal can be cut in different ways. Crystal cut perpendicular to the *x-axis* is called *x-cut crystal* whereas that cut perpendicular to *y-axis* is called *y-cut crystal*. The piezoelectric properties of a crystal depend upon its cut.

Frequency of crystal. Each crystal has a natural frequency like a pendulum. The natural frequency f of a crystal is given by :

$$f = \frac{K}{t}$$

where K is a constant that depends upon the cut and t is the thickness of the crystal. It is clear that frequency is inversely proportional to crystal thickness. The thinner the crystal, the greater is its natural frequency and *vice-versa*. However, extremely thin crystal may break because of vibrations. This puts a limit to the frequency obtainable. In practice, frequencies between 25 kHz to 5 MHz have been obtained with crystals.



Piezoelectric Crystals

14.17 Working of Quartz Crystal

In order to use crystal in an electronic circuit, it is placed between two metal plates. The arrangement then forms a capacitor with crystal as the dielectric as shown in Fig. 14.20. If an a.c. voltage is applied across the plates, the crystal will start vibrating at the frequency of applied voltage. However, if the frequency of the applied voltage is made equal to the natural frequency of the crystal, resonance takes place and crystal vibrations reach a maximum value. This natural frequency is almost constant. Effects of temperature change can be eliminated by mounting the crystal in a temperature-controlled oven as in radio and television transmitters.

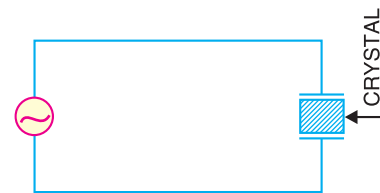

Fig. 14.20

14.18 Equivalent Circuit of Crystal

Although the crystal has electromechanical resonance, we can represent the crystal action by an equivalent electrical circuit.

- (i) When the crystal is not vibrating, it is equivalent to capacitance C_m because it has two metal plates separated by a dielectric [See Fig. 14.21 (i)]. This capacitance is known as *mounting capacitance*.

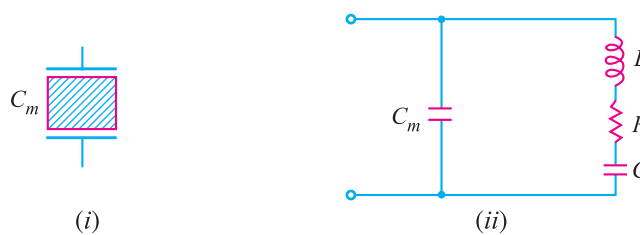

Fig. 14.21

382 ■ Principles of Electronics

- (ii) When a crystal vibrates, *it is equivalent to $R-L-C$ series circuit. Therefore, the equivalent circuit of a vibrating crystal is $R-L-C$ series circuit shunted by the mounting capacitance C_m as shown in Fig. 14.21 (ii).

C_m = mounting capacitance

$R-L-C$ = electrical equivalent of vibrational characteristic of the crystal

Typical values for a 4 MHz crystal are :

$$L = 100 \text{ mH} \quad ; \quad R = 100 \Omega$$

$$C = 0.015 \text{ pF} \quad ; \quad C_m = 5 \text{ pF}$$

$$\begin{aligned} \therefore \quad Q\text{-factor of crystal} &= \frac{1}{R} \sqrt{\frac{L}{C}} \\ &= \frac{1}{100} \sqrt{\frac{100 \times 10^{-3}}{0.015 \times 10^{-12}}} = 26,000 \end{aligned}$$

Note that Q of crystal is very high. The extremely high Q of a crystal leads to frequency **stability.

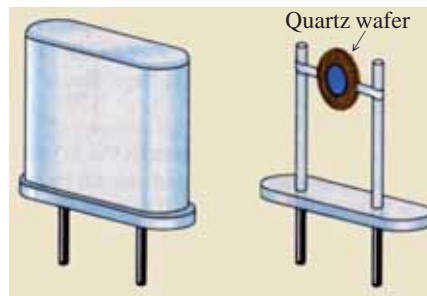

A quartz crystal

14.19 Frequency Response of Crystal

When the crystal is vibrating, its equivalent electrical circuit is as shown in Fig. 14.22 (i). The capacitance values of C and C_m are relatively low (less than 1 pF for C and 4–40 pF for C_m). Note that the value of C is much lower than that of C_m .

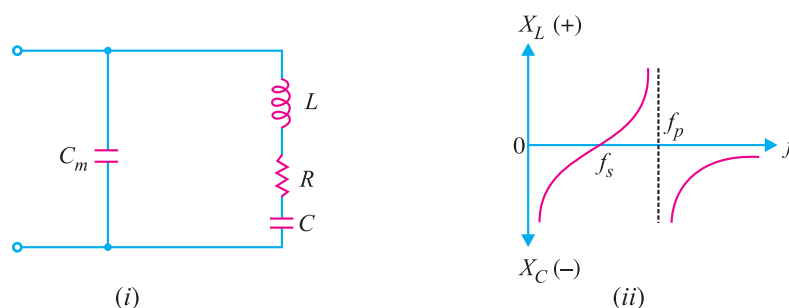

Fig. 14.22

- (i) At low frequencies, the impedance of the crystal is controlled by extremely high values of X_{C_m} and X_C . In other words, at low frequencies, the impedance of the network is high and capacitive as shown in Fig. 14.22 (ii).
- (ii) As the frequency is increased, $R-L-C$ branch approaches its resonant frequency. At some definite frequency, the reactance X_L will be equal to X_C . The crystal now acts as a series-

* When the crystal is vibrating, L is the electrical equivalent of crystal mass, C is the electrical equivalent of elasticity and R is electrical equivalent of mechanical friction.

** When Q is high, frequency is primarily determined by L and C of the crystal. Since these values remain fixed for a crystal, the frequency is stable. However, in ordinary LC tank circuit, the values of L and C have large tolerances.

resonant circuit. For this condition, the impedance of the crystal is very low; being equal to R . The frequency at which the vibrating crystal behaves as a series-resonant circuit is called *series-resonant frequency* f_s . Its value is given by:

$$f_s = \frac{1}{2\pi \sqrt{LC}} \text{ Hz}$$

where L is in henry and C is in farad.

(iii) At a slightly higher frequency, the net reactance of branch $R-L-C$ becomes inductive and equal to X_{C_m} . The crystal now acts as a parallel-resonant circuit. For this condition, the crystal offers a very high impedance. The frequency at which the vibrating crystal behaves as a parallel-resonant circuit is called *parallel-resonant frequency* f_p .

$$f_p = \frac{1}{2\pi \sqrt{LC_T}}$$

where

$$C_T = \frac{C \times C_m}{C + C_m}$$

Since C_T is less than C , f_p is always greater than f_s . Note that frequencies f_s and f_p are very close to each other.

(iv) At frequencies greater than f_p , the value of X_{C_m} drops and eventually the crystal acts as a short circuit.

Conclusion. The above discussion leads to the following conclusions :

- (i) At f_s , the crystal will act as a series-resonant circuit.
- (ii) At f_p , the crystal will act as a parallel-resonant circuit.

Therefore, we can use a crystal in place of a series LC circuit or in place of parallel LC circuit. If we use it in place of series LC circuit, the oscillator will operate at f_s . However if we use the crystal in place of parallel LC circuit, the oscillator will operate at f_p . In order to use the crystal properly, it must be connected in a circuit so that its low impedance in the series resonant operating mode or high impedance in the parallel resonant operating mode is selected.

14.20 Transistor Crystal Oscillator

Fig. 14.23 shows the transistor crystal oscillator. Note that it is a Collpit's oscillator modified to act as a crystal oscillator. The only change is the addition of the crystal (Y) in the feedback network. The crystal will act as a parallel-tuned circuit. As you can see in this circuit that instead of

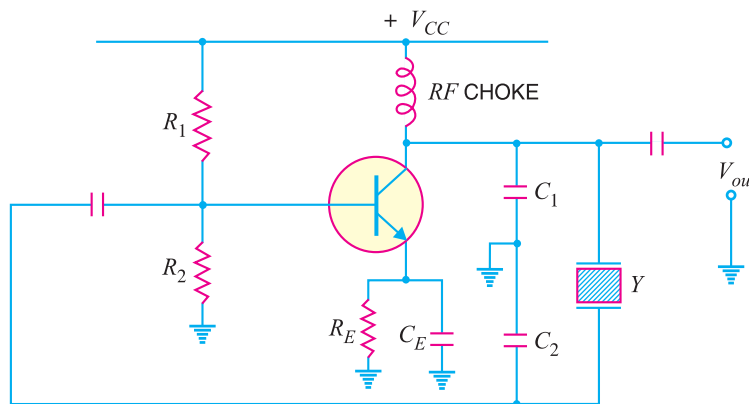

Fig. 14.23

384 ■ Principles of Electronics

resonance caused by L and $(C_1 + C_2)$, we have the parallel resonance of the crystal. At parallel resonance, the impedance of the crystal is maximum. This means that there is a maximum voltage drop across C_1 . This in turn will allow the maximum energy transfer through the feedback network at f_p .

Note that feedback is positive. A phase shift of 180° is produced by the transistor. A further phase shift of 180° is produced by the capacitor voltage divider. This oscillator will oscillate only at f_p . Even the smallest deviation from f_p will cause the oscillator to act as an effective short. Consequently, we have an extremely stable oscillator.

Advantages

- (i) They have a high order of frequency stability.
- (ii) The quality factor (Q) of the crystal is very high. The Q factor of the crystal may be as high as 10,000 compared to about 100 of L - C tank.

Disadvantages

- (i) They are fragile and consequently can only be used in low power circuits.
- (ii) The frequency of oscillations cannot be changed appreciably.

Example 14.10. A crystal has a thickness of t mm. If the thickness is reduced by 1%, what happens to frequency of oscillations ?

Solution. Frequency, $f = \frac{K}{t}$

or $f \propto \frac{1}{t}$

If the thickness of the crystal is reduced by 1%, the frequency of oscillations will increase by 1%.

Example 14.11. The ac equivalent circuit of a crystal has these values: $L = 1\text{ H}$, $C = 0.01\text{ pF}$, $R = 1000\ \Omega$ and $C_m = 20\text{ pF}$. Calculate f_s and f_p of the crystal.

Solution.

$$L = 1\text{ H}$$

$$C = 0.01\text{ pF} = 0.01 \times 10^{-12}\text{ F}$$

$$C_m = 20\text{ pF} = 20 \times 10^{-12}\text{ F}$$

$$\begin{aligned} \therefore f_s &= \frac{1}{2\pi\sqrt{LC}} \\ &= \frac{1}{2\pi\sqrt{1 \times 0.01 \times 10^{-12}}}\text{ Hz} \end{aligned}$$

$$= 1589 \times 10^3\text{ Hz} = \mathbf{1589\text{ kHz}}$$

Now
$$C_T = \frac{C \times C_m}{C + C_m} = \frac{0.01 \times 20}{0.01 + 20} = 9.99 \times 10^{-3}\text{ pF}$$

$$= 9.99 \times 10^{-15}\text{ F}$$

$$\begin{aligned} \therefore f_p &= \frac{1}{2\pi\sqrt{LC_T}} \\ &= \frac{1}{2\pi\sqrt{1 \times 9.99 \times 10^{-15}}}\text{ Hz} \end{aligned}$$

$$= 1590 \times 10^3\text{ Hz} = \mathbf{1590\text{ kHz}}$$

If this crystal is used in an oscillator, the frequency of oscillations will lie between 1589 kHz and 1590 kHz.

MULTIPLE-CHOICE QUESTIONS

1. An oscillator converts
 - (i) a.c. power into d.c. power
 - (ii) d.c. power into a.c. power
 - (iii) mechanical power into a.c. power
 - (iv) none of the above
2. In an LC transistor oscillator, the active device is
 - (i) LC tank circuit (ii) biasing circuit
 - (iii) transistor (iv) none of the above
3. In an LC circuit, when the capacitor energy is maximum, the inductor energy is
 - (i) minimum (ii) maximum
 - (iii) half-way between maximum and minimum
 - (iv) none of the above
4. In an LC oscillator, the frequency of oscillator is L or C .
 - (i) proportional to square of
 - (ii) directly proportional to
 - (iii) independent of the values of
 - (iv) inversely proportional to square root of
5. An oscillator produces oscillations.
 - (i) damped (ii) undamped
 - (iii) modulated (iv) none of the above
6. An oscillator employs feedback.
 - (i) positive (ii) negative
 - (iii) neither positive nor negative
 - (iv) data insufficient
7. An LC oscillator cannot be used to produce frequencies.
 - (i) high (ii) audio
 - (iii) very low (iv) very high
8. Hartley oscillator is commonly used in
 - (i) radio receivers (ii) radio transmitters
 - (iii) TV receivers (iv) none of the above
9. In a phase shift oscillator, we use RC sections.
 - (i) two (ii) three
 - (iii) four (iv) none of the above
10. In a phase shift oscillator, the frequency determining elements are
 - (i) L and C (ii) R , L and C
 - (iii) R and C (iv) none of the above
11. A Wien bridge oscillator uses feedback.
 - (i) only positive (ii) only negative
 - (iii) both positive and negative
 - (iv) none of the above
12. The piezoelectric effect in a crystal is
 - (i) a voltage developed because of mechanical stress
 - (ii) a change in resistance because of temperature
 - (iii) a change of frequency because of temperature
 - (iv) none of the above
13. If the crystal frequency changes with temperature, we say that crystal has temperature coefficient.
 - (i) positive (ii) zero
 - (iii) negative (iv) none of the above
14. The crystal oscillator frequency is very stable due to of the crystal.
 - (i) rigidity (ii) vibrations
 - (iii) low Q (iv) high Q
15. The application where one would most likely find a crystal oscillator is
 - (i) radio receiver (ii) radio transmitter
 - (iii) AF sweep generator
 - (iv) none of the above
16. An oscillator differs from an amplifier because it
 - (i) has more gain
 - (ii) requires no input signal
 - (iii) requires no d.c. supply
 - (iv) always has the same input
17. One condition for oscillation is
 - (i) a phase shift around the feedback loop of 180°
 - (ii) a gain around the feedback loop of one-third

386 ■ Principles of Electronics

- (iii) a phase shift around the feedback loop of 0°
 (iv) a gain around the feedback loop of less than 1
- 18.** A second condition for oscillations is
- (i) a gain of 1 around the feedback loop
 (ii) no gain around the feedback loop
 (iii) the attenuation of the feedback circuit must be one-third
 (iv) the feedback circuit must be capacitive
- 19.** In a certain oscillator, $A_v = 50$. The attenuation of the feedback circuit must be
- (i) 1 (ii) 0.01
 (iii) 10 (iv) 0.02
- 20.** For an oscillator to properly start, the gain around the feedback loop must initially be
- (i) 1 (ii) greater than 1
 (iii) less than 1
 (iv) equal to attenuation of feedback circuit
- 21.** In a Wien-bridge oscillator, if the resistances in the positive feedback circuit are decreased, the frequency
- (i) remains the same
 (ii) decreases
 (iii) increases
 (iv) insufficient data
- 22.** In a Colpitt's oscillator, feedback is obtained
- (i) by magnetic induction
 (ii) by a tickler coil
 (iii) from the centre of split capacitors
 (iv) none of the above
- 23.** The Q of a crystal is of the order of
- (i) 100 (ii) 1000
 (iii) 50 (iv) more than 10,000
- 24.** Quartz crystal is most commonly used in crystal oscillators because
- (i) it has superior electrical properties
 (ii) it is easily available
 (iii) it is quite inexpensive
 (iv) none of the above
- 25.** In LC oscillators, the frequency of oscillations is given by
- (i) $\frac{2\pi}{\sqrt{LC}}$ (ii) $\frac{1}{2\pi\sqrt{LC}}$
 (iii) $\frac{\sqrt{LC}}{2\pi}$ (iv) $\frac{2\pi L}{\sqrt{LC}}$
- 26.** The operating frequency of a Wien-bridge oscillator is given by
- (i) $\frac{1}{2\pi\sqrt{LC}}$ (ii) $\frac{1}{4\pi\sqrt{LC}}$
 (iii) $\frac{1}{2\pi RC}$ (iv) $\frac{1}{29 RC}$
- 27.** is a fixed frequency oscillator.
- (i) Phase-shift oscillator
 (ii) Hartley oscillator
 (iii) Colpitt's oscillator
 (iv) Crystal oscillator
- 28.** In an LC oscillator, if the value of L is increased four times, the frequency of oscillations is
- (i) increased 2 times
 (ii) decreased 4 times
 (iii) increased 4 times
 (iv) decreased 2 times
- 29.** An important limitation of a crystal oscillator is
- (i) its low output (ii) its high Q
 (iii) less availability of quartz crystal
 (iv) its high output
- 30.** The signal generator generally used in the laboratories is oscillator.
- (i) Wien-bridge (ii) Hartley
 (iii) Crystal (iv) Phase shift

Answers to Multiple-Choice Questions

1. (ii)	2. (iii)	3. (i)	4. (iv)	5. (ii)
6. (i)	7. (iii)	8. (i)	9. (ii)	10. (iii)
11. (iii)	12. (i)	13. (i)	14. (iv)	15. (ii)
16. (ii)	17. (iii)	18. (i)	19. (iv)	20. (ii)
21. (iii)	22. (iii)	23. (iv)	24. (i)	25. (ii)
26. (iii)	27. (iv)	28. (iv)	29. (i)	30. (i)

Chapter Review Topics

1. What is an oscillator ? What is its need ? Discuss the advantages of oscillators.
2. What do you understand by damped and undamped electrical oscillations ? Illustrate your answer with examples.
3. Explain the operation of a tank circuit with neat diagrams.
4. What is the nature of oscillations produced by tank circuit ?
5. How will you get undamped oscillations from a tank circuit ?
6. Discuss the essentials of an oscillator.
7. Discuss the circuit operation of tuned collector oscillator.
8. With a neat diagram, explain the action of Hartley and Colpitt's oscillators.
9. What are the drawbacks of LC oscillators ?
10. Write short notes on the following :
 - (i) RC oscillators
 - (ii) Wien bridge oscillators
 - (iii) Crystal oscillator

Problems

1. Figure 14.24 shows the Colpitt's oscillator. Determine the (i) operating frequency and (ii) feedback fraction. [(i) 24.5 kHz (ii) 0.1]

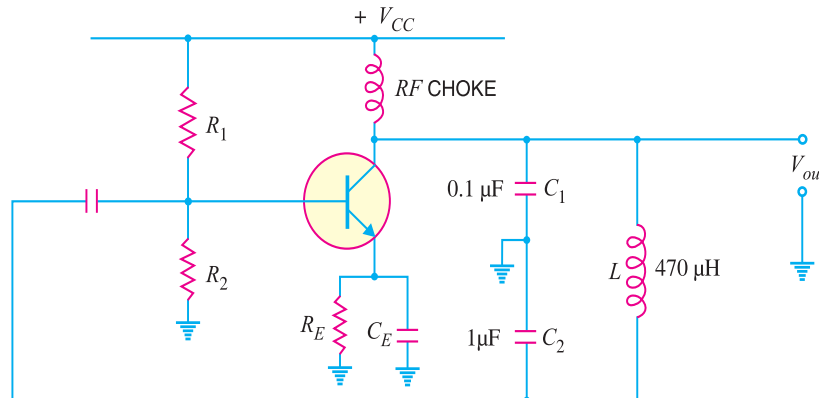

Fig. 14.24

2. Figure 14.25 shows the Hartley oscillator. If $L_1 = 1000 \mu\text{H}$, $L_2 = 100 \mu\text{H}$ and $C = 20 \text{ pF}$, find the (i) operating frequency and (ii) feedback fraction. [(i) 1052 kHz (ii) 0.1]
3. For the Colpitt's oscillator shown in Fig. 14.24, $C_1 = 750 \text{ pF}$, $C_2 = 2500 \text{ pF}$ and $L = 40 \mu\text{H}$. Determine (i) the operating frequency and (ii) feedback fraction. [(i) 1050 kHz (ii) 0.3]

388 ■ Principles of Electronics

4. For the Hartley oscillator shown in Fig. 14.25, $C = 250$ pF, $L_1 = 1.5$ mH, $L_2 = 1.5$ mH and $M = 0.58$ mH. Determine the operating frequency. [159.2 kHz]

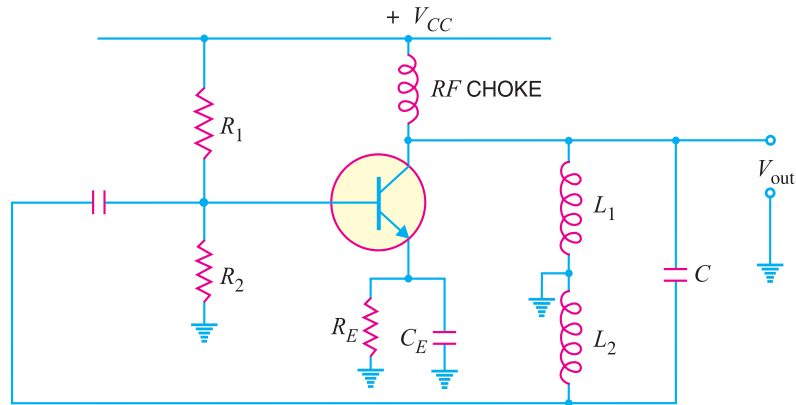

Fig. 14.25

5. A crystal has $L = 3H$, $C = 0.05$ pF, $R = 2$ k Ω and $C_m = 10$ pF. Calculate the series-resonant and parallel-resonant frequencies of the crystal. [411 kHz ; 412 kHz]

Discussion Questions

1. Why is amplifier circuit necessary in an oscillator ?
2. Why is crystal oscillator used in radio transmitter ?
3. Why do you use three RC sections in RC oscillator ?
4. Why is negative feedback provided in Wien bridge oscillators ?
5. Why is quartz crystal commonly used in crystal oscillators ?